

For Serial Nos.  
440,000 & Higher

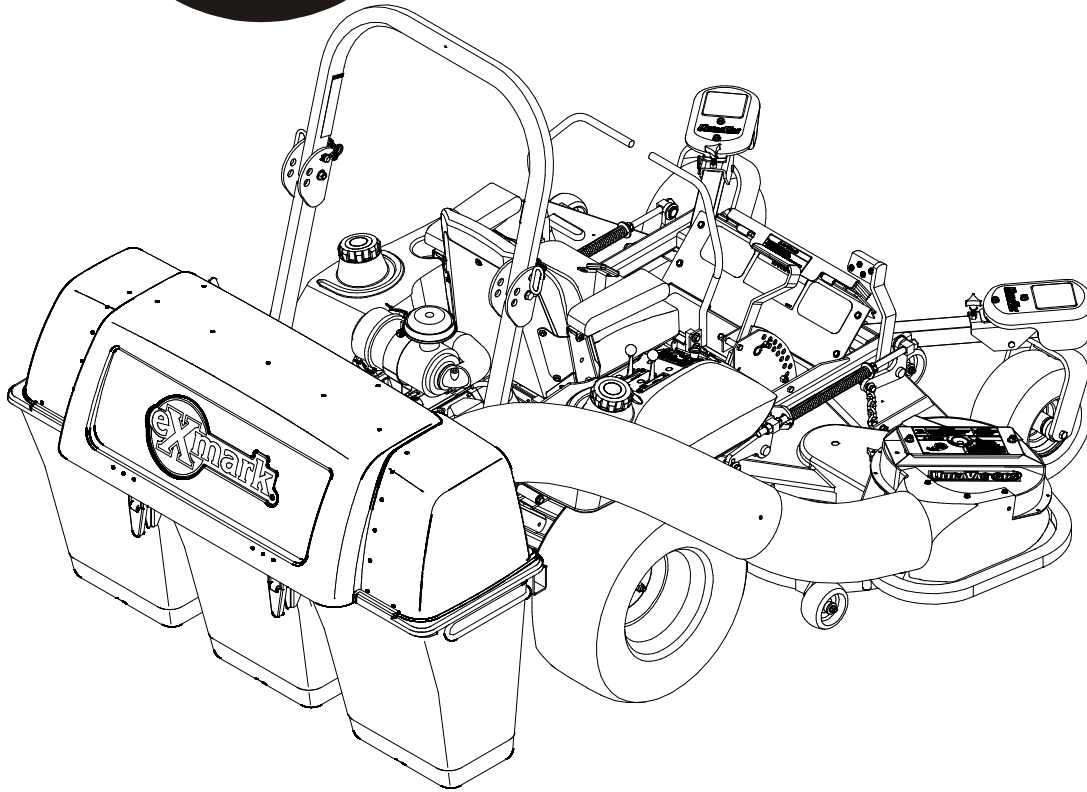

PARTS MANUAL

# ULTRA VAC<sup>TM</sup>

## LAZER Z<sup>®</sup> AND LAZER Z XP<sup>®</sup> MODELS

**CONGRATULATIONS** on the purchase of your new Exmark equipment. This product has been carefully designed and manufactured to give you a maximum amount of dependability and years of trouble-free operation. If additional information is needed, or should you require trained mechanic service, contact your authorized Exmark equipment dealer or distributor. If you need to order replacement parts from your dealer, always give the model number and serial number of your equipment as well as the part number, description and quantity of the part needed.

The Serial No. plate is located on the front mount of the hopper assembly. For ease of ordering and reference, we suggest that you record the information requested in the following identification table.

Place Model No. and Serial No. Label Here  
(Included in Literature Pack)  
or Fill in Below

Model No. \_\_\_\_\_

Serial No. \_\_\_\_\_

Date Purchased \_\_\_\_\_

# EXMARK PARTS PLUS<sup>o</sup> PROGRAM

EFFECTIVE DATE: September 1, 1995

## Program

If your Exmark dealer does not have the Exmark part in stock, Exmark will get the parts to the dealer the next business day or the part will be FREE\* Guaranteed!!

## **How the Program Works**

1. If dealer does not have part in stock for a "down" unit at the time of request by customer, the dealer contacts his distributor by 1:00 p.m., local time, and requests Exmark Parts Plus<sup>o</sup> shipment of six (6) line items or less.
2. Distributor ships part(s) to dealer or customer, as requested by dealer, same day, overnight UPS. Distributor bills dealer for part and freight charges where applicable.
3. If distributor does not have the part(s) in stock to satisfy Exmark Parts Plus<sup>o</sup> order, he contacts Exmark by 3:00 p.m., central time, with an Exmark Parts Plus<sup>o</sup> order of six (6) line items or less.
4. If order is received by 3:00 p.m. central time, Exmark ships part(s) direct to dealer or customer, as requested by distributor, same day, overnight UPS. Exmark bills the distributor for parts and shipping charges, where applicable.
5. The customer pays for the part and freight if it is shipped under the Exmark Parts Plus<sup>o</sup> and if it arrives in accordance to the program.
6. Who pays for the part and freight if it fails to arrive overnight in accordance to the program?
  - A. Under any circumstance the customer does not pay.
  - B. If the part does not arrive overnight due to:
    1. The dealer not submitting the Exmark Parts Plus<sup>o</sup> order to his Exmark distributor by 1:00 p.m., the dealer pays for the part and freight.
    2. The Distributor being unable to ship the part the same day or not submitting the Exmark Parts Plus<sup>o</sup> order to Exmark by 3:00 p.m., central time, the Distributor pays for the part and freight.
    3. Exmark being unable to ship the part and the Exmark parts order is received by 3:00 p.m., central time, Exmark pays for the part and freight.
    4. If the part does not arrive overnight due to the shipper (UPS), the shipper pays for the freight and Exmark pays for the part.

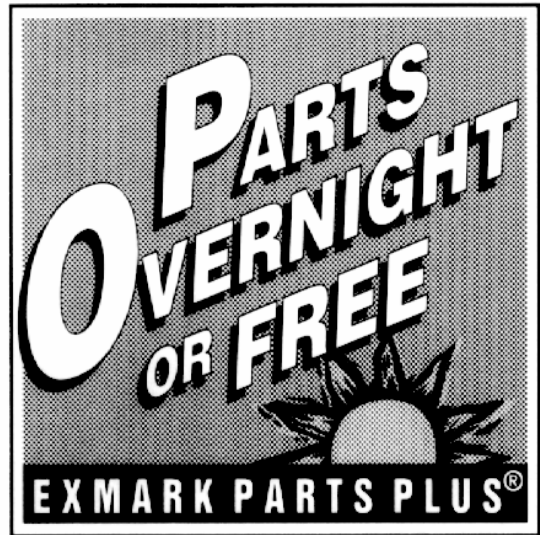

**The following restrictions apply** -- The Exmark Parts Plus<sup>o</sup> Program is available only through participating Exmark Dealers and applies only to orders submitted on this program Monday through Thursday. Parts Plus service is available only in the contiguous 48 United States. UPS has initiated a Saturday delivery program to many areas of the continental United States and can be requested for an overnight shipment on Friday to be delivered Saturday. The next day air charge, plus the Saturday delivery fee will be the responsibility of the purchaser. Exmark Mfg. will assume no responsibility for Saturday delivery shipments. To qualify, all Exmark Parts Plus<sup>o</sup> orders must be received by Exmark by 3:00 p.m., central time. Orders must be six (6) line items or less. Exclusions from the Exmark Parts Plus<sup>o</sup> Program are: Any wholegood or accessory in its entirety, engines and engine replacement parts, 5-speed Peerless transmissions and 5-speed transaxles, hydraulic or hydrostatic wheel motors, cutter decks and engine decks or any item exceeding United Parcel Service size and weight restrictions.

Due to UPS restrictions, aerosol spray paint is considered a hazardous material and cannot be shipped via UPS next day or Second Day Air.

Exmark Manufacturing stocks a limited supply of parts for transaxles, pumps and wheel motors. These parts can be ordered for Next Day Air shipment but will not be guaranteed per the Parts Plus Program.



**READ OPERATOR'S MANUAL BEFORE  
OPERATING OR SERVICING EXMARK EQUIPMENT**

## **TABLE OF CONTENTS**

<b><u>Description</u></b>	<b><u>Page</u></b>
Blower Assembly – Lazer Z 52" .....	3-4
Blower Assembly – Lazer Z & Lazer XP (60" & 72").....	5-6
Decals.....	13
Hood and Bag Assembly – Lazer Z 52" .....	7-8
Hood and Bag Assembly – Lazer Z & Lazer Z XP (60" & 72")....	9-10
Weight and Belt Drive Components .....	11-12

## BLOWER ASSEMBLY – LAZER Z 52”

Item	Part No.	Description	Qty.
1▲	103-2875-03	Wld, Blower Mount.....	1
2	103-3815	Wld, Impeller .....	1
3+	1-653346	Bearing, SPH. OD.....	2
4	1-513013	Housing, Flange .....	4
5+	103-1047	Sheave, Blower .....	1
6	103-3592	Wld, Upper Housing (1-652345-03) With Decals .....	1
7	1-653331	Spring, Idler .....	1
8	3290-357	Nut, Whizlock 3/8-16.....	8
9	323-7	Screw, HH 3/8-16 x 1 1/4.....	1
10	323-11	Screw, HH 3/8-16 x 2 1/4.....	3
11	323-12	Screw, HH 3/8-16 x 2 1/2.....	2
12	3256-4	Washer, 3/8 Std.....	4
13	103-4171	Chute, Blower.....	1
14	1-353054	Latch, Grass Catcher.....	1
15	3296-39	Nut, Nyloc 3/8-16.....	1
16	1-653322	Pulley, Idler.....	1
17	103-0130	Bushing, Idler Pivot.....	1
18	1-653352-01	Bumper.....	1
19	103-2876	Asm , Idler W/Bushings Zerk, & Decal.....	1
20	3230-18	Bolt, Carriage 5/16-18 x 5/8.....	6
21	1-513208	Washer, Spring Disk.....	1
22	3219-6	Nut, Hex 5/8-18 .....	1
23	3220-5	Nut, Jam 1/2-20 .....	1
24	1-513435	Washer, Spring Disk.....	1
25	1-653365	Spacer.....	1
26	1-653366	Hub.....	1
27	32128-20	Nut, Whizlock 5/16-18.....	6
28	3290-500	Screw, PPH #10-24 x 5/8.....	4
29	321-3	Screw, HH 1/4-20 x 5/8.....	8
30	32128-33	Nut, Whizlock 1/4-20.....	15
31	1-303334	Washer, Spring Disk 5/16 .....	1
32	3229-11	Bolt, Carriage 1/4-20 x 5/8.....	5

Item	Part No.	Description	Qty.
33	103-0126	Bushing, Locator .....	1
34	3257-32	Key, Woodruff #61 5/8 x 3/16 .....	1
35	103-3585	Cover, Bearing (103-3586-03) With Decal.....	1
36	3296-29	Nut, Nyloc 5/16-18.....	2
37	3256-3	Washer, 5/16 Std.....	2
38	3274-18	Screw, Socket HD 5/16-18 x 1 1/4.....	1
39	1-803075	Screw, CRTH #10-24 x 3/4.....	8
40	3290-148	Nut, Whizlock #10-24 .....	3
41	1-803076	Screw, CRTH 1/4-20 x 3/4.....	2
42	3274-107	Screw, Socket But HD 3/8-16 x 1 3/4.....	1
43	1-353050	Pin, Grass Catcher .....	1
44	1-806323	Roll pin .....	1
45	1-653596-03	Plate, Blower Backing.....	1
46	302-19	Zerk, 1/8-28 Straight.....	1
47	3256-24	Washer, 3/8 SAE .....	1
48	1-653443-03	Plate, Filler (Below S/N 260,000).....	1
49	103-1042-03	Plate, Blocker .....	1
50	3217-6	Nut, Hex 5/16-18 .....	1
51	103-1103	Pulley, Idler .....	1
52	1-653429	Asm, Latch .....	2
53	323-8	Screw, HH 3/8-16 x 1 1/2.....	1
54	1-653600	Bearing.....	2
55	3256-14	Washer, #10 Std.....	4
56	103-4752-03	Plate, Reinforcing (Below S/N 260,000)..	1
57	3290-500	Screw, PPH #10-24 x 5/8 .....	2
58	3296-2	Nut, Nyloc #10-24.....	3
59	3256-14	Washer, #10 Std.....	5
60	103-4176	Tube, Lower .....	1
61	103-0811	Tube, Upper 52” .....	1
62	32105-13	Screw, Slotted HH #10-24 x 3/4 .....	3
63	103-1209	Asm, Blower, (Includes Items 1-56 & Decals).....	1

Exmark red touch up spray paint - P/N 1-850337.

Kit 103-0583 is available to add or repair the welded-on accessory mounting tube on all 44"-72" decks.

✚ Apply Mobil HTS grease (P/N 103-5217 1.5 oz packet) (or a food-grade antisieze) on bore of sheave and bearings.

▲ Includes items 43 and 44.

# BLOWER ASSEMBLY – LAZER 52"

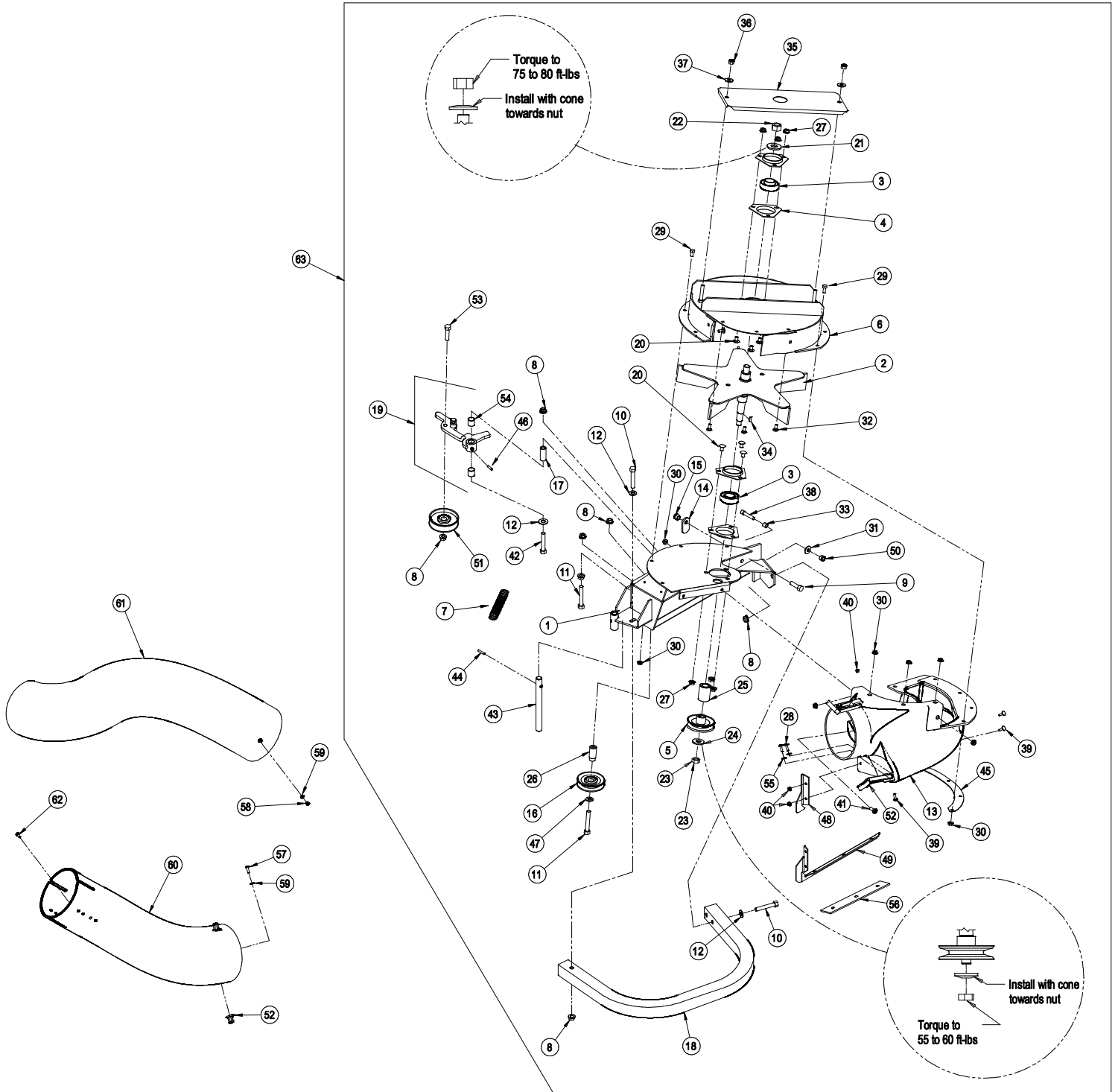

## BLOWER ASSEMBLY – LAZER Z & LAZER Z XP (60" & 72")

Item	Part No.	Description	Qty.
1	103-0454-03	Wld, Blower Mount 60"&72" .....	1
2	103-0455	Wld, Impeller .....	1
3+	1-653346	Bearing, SPH. OD.....	2
4	1-513013	Housing, Flange .....	4
5+	103-0456	Sheave, Blower .....	1
6	103-3593	Wld, Upper Housing (103-0457-03) With Decals .....	1
7	1-653331	Spring, Idler .....	1
8	3290-357	3/8-16 Whizlock Nut.....	8
9	323-7	Screw HH 3/8-16 x 1 1/4.....	1
10	323-11	Screw HH 3/8-16 x 2 1/4.....	4
11	3256-4	Washer, Flat .438 x 1.00 x .083 .....	4
12	103-4759	Chute, Blower.....	1
13	1-353054	Latch, Grass Catcher.....	1
14	3296-39	Nut, Nyloc 3/8-16.....	1
15	1-603044	Bushing, Idler Pivot.....	1
16	103-0458-01	Bumper.....	1
17	103-0448	Asm , Idler W/Bushings (103-0462-03) Zerk, & Decal.....	1
18	3230-18	Bolt, Carriage 5/16-18 x 5/8.....	6
19	1-513208	Washer, Spring Disk.....	1
20	3219-6	Nut, 5/8-18.....	1
21	3220-5	Nut, Jam 1/2-20.....	1
22	1-513435	Washer, Spring Disk.....	1
23	103-0460	Spacer.....	1
24	32128-20	Nut, Whizlock 5/16-18.....	6
25	321-4	Screw, HH 1/4-20 x 3/4.....	2
26	321-3	Screw, HH 1/4-20 x 5/8.....	10
27	32128-33	Nut, Whizlock 1/4-20.....	17
28	1-303334	Washer, Spring Disk 5/16 .....	1
29	3229-11	Bolt, Carriage 1/4-20 x 5/8.....	5
30	103-0126	Bushing, Locator.....	1
31	3257-32	Key, Woodruff #61 5/8 x 3/16.....	1

Item	Part No.	Description	Qty.
32	103-3583	Cover, Bearing (103-3584-03) With Decal.....	1
33	3296-29	Nut, Nyloc 5/16-18.....	2
34	3256-3	Washer, Flat 5/16 x 7/8 OD .....	2
35	3274-18	Screw, Socket HD 5/16-18 x 1 1/4.....	1
36	1-803075	Screw, CRTH #10-24 x 3/4.....	3
37	3290-148	Nut, Whizlock #10-24 .....	3
38	1-803076	Screw, CRTH 1/4-20 x 3/4.....	2
39	323-8	Screw HH 3/8-16 x 1 1/2.....	1
40	103-2898	Latch, Rubber.....	2
41	3217-6	Nut 5/16-18 .....	1
42	103-0461-03	Plate, Blower Backing.....	1
43	323-4	Screw HH 3/8-16 x 3/4 .....	3
44	302-19	Zerk, 1/8-28 Straight.....	1
45	103-0483	Pulley, Idler .....	1
46	1-653367	Hub, Spacer .....	1
47	1-653600	Bearing.....	2
48	103-3093	Plate, Backing .....	2
49	103-0445-03	Wld, Mount Pin.....	1
50	32105-13	Screw, HWH #10-24 x 3/4 .....	10
51	103-4170	Tube, Lower .....	1
52	103-0424	Tube, Upper 60" .....	1
	103-0425	Tube, Upper 72" .....	1
53	103-2897	Latch, Catch .....	2
54	3256-61	Washer, Flat .216 x .75 x .05.....	6
55	3296-2	Nut, Nyloc #10-24.....	10
56	321-6	Screw, HH 1/4-20 x 1 .....	2
57	103-3079	Plate, Backing .....	2
58	1-353005-03	Handle.....	1
59	3296-42	Nut, Nyloc 1/4-20.....	4
60	3256-55	Washer, Flat .26 x 1.25 .....	2
61	103-2991	Asm, Blower, 60" & 72" (Includes Items 1-49 & Decals).....	1

Exmark red touch up spray paint - P/N 1-850337.

Kit 103-0583 is available to add or repair the welded-on accessory mounting tube on all 44"-72" decks.

✚ Apply Mobil HTS grease (P/N 103-5217 1.5 oz packet) (or a food-grade antisieze) on bore of sheave and bearings.

# BLOWER ASSEMBLY – LAZER Z & LAZER Z XP (60" & 72")

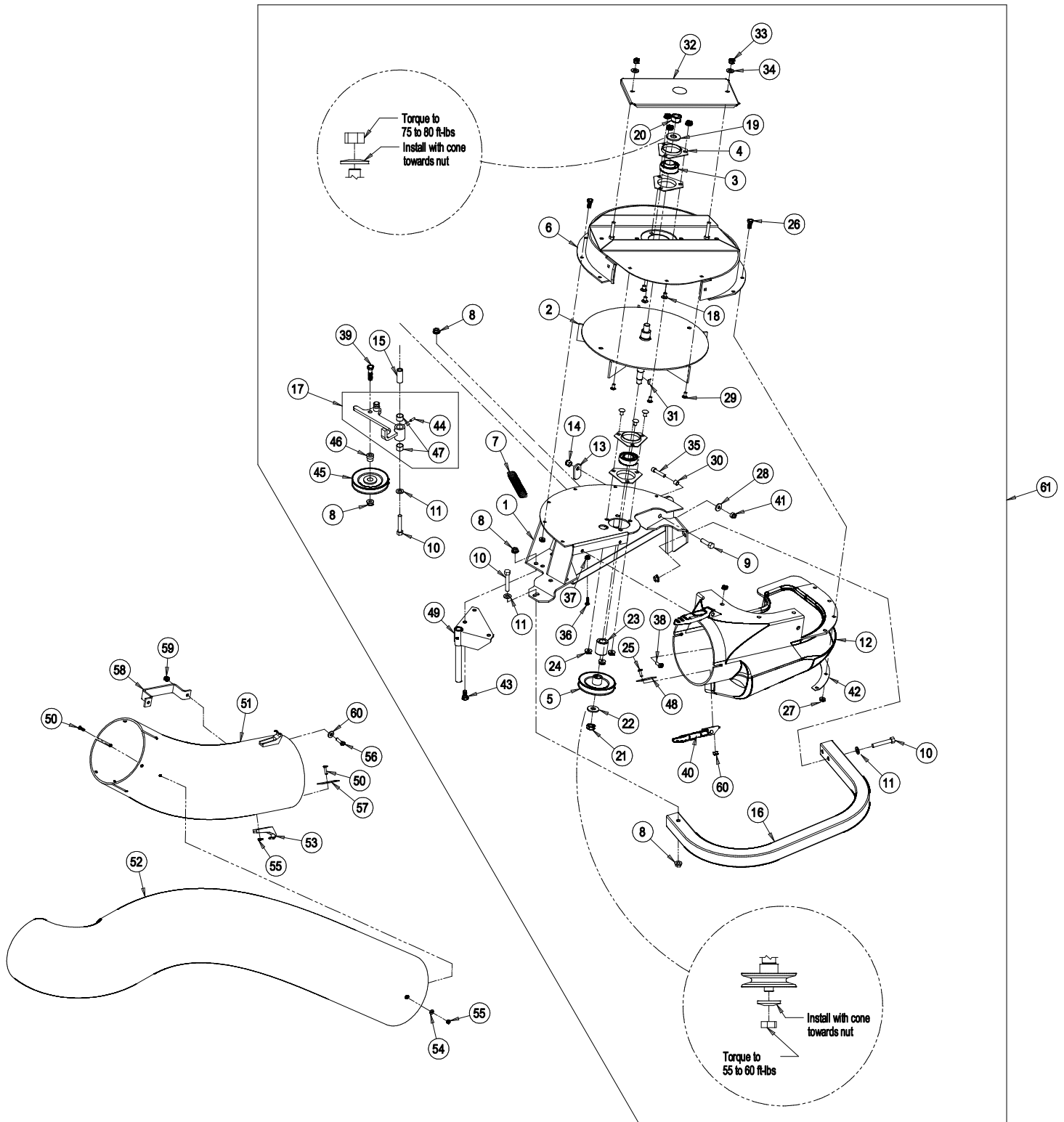

## HOOD and BAG ASSEMBLY – LAZER Z 52”

Item	Part No.	Description	Qty.
1◆	1-654597	Asm, Hood.....	1
2	1-653397-03	Stiffener, Bagger Top.....	1
3	103-0825-03	Wld, Hinge (RH) .....	1
	103-0826-03	Wld, Hinge (LH) .....	1
4	114967	Screen.....	1
5	114439	Rivet, Pop 3/16 x 1/2 .....	38
6	1-803075	Screw, Truss HD #10-24 x 3/4.....	6
7	3256-61	Washer, 216 x .750 x .049.....	14
8	3296-2	Nut, Nyloc #10-24.....	4
9	1-653561	Seal, Chute.....	1
10	1-653598-03	Clamp, Seal.....	1
11	103-1346	Seal.....	1
12	1-653400-03	Support, Screen.....	1
13	1-653519	Mount, Latch.....	1
14	1-653036	Washer, .344 x 1.75 x .062 Pltd.....	2
15	321-4	Screw, HH 1/4-20 x 3/4.....	6
16	32128-33	Nut, Whizlock 1/4-20.....	6
17	1-653403	Latch .....	1
18	1-653535	Reinforcement, Latch.....	1
19	321-11	Screw, HH 1/4-20 x 2.....	1
20	3274-55	Screw, HSBH 5/16-18 x 3/4.....	2
21	3296-42	Nut, Nyloc 1/4-20.....	3
22	321-6	Screw, HH 1/4-20 x 1.....	2
23	103-4741-03	Wld, Bagger Upright .....	1
24	3256-2	Washer, 1/4 Std.....	2
25	1-633545	Spacer.....	2
26	1-653544	Spring.....	2
27	322-3	Screw, HH 5/16-18 x 3/4.....	2
28	1-653528-03	Plate, Backing.....	1

Item	Part No.	Description	Qty.
29	1-653529-03	Frame, Bag .....	1
30	114973-03	Hanger, Bag.....	1
31	114974-03	Clamp.....	1
32	3230-1	Bolt, Carriage 5/16-18 x 3/4.....	2
33	3296-29	Nut, Nyloc 5/16-18.....	2
34	103-0431	Bag, Cloth .....	1
35	1-653566	Handle, Bag .....	1
36	3229-1	Bolt, Carriage 1/4-20 x 3/4.....	2
37	1-653036	Washer, .344 x 1.75 x .062 Pltd.....	2
38	3296-42	Nut, Nyloc 1/4-20.....	2
39	1-653404	Catch.....	1
40	3290-500	Screw, PPH #10-24 x 5/8 .....	2
41	3290-148	Nut, Whizlock #10-24 .....	2
42	103-5124-03	Wld, Bag Support .....	1
43	32128-33	Nut, Whizlock 1/4-20 .....	1
44	1-523420	Bumper .....	1
45	103-0435	Asm, Bag.....	1
46	32153-1	Nut, Side Lock #10-24 .....	6
47	71-9310	Spacer (LZ) .....	6
48	283-69	Clevis Pin .....	2
49	1-806005	Hairpin, Cotter .....	2
50	3250-27	Screw, PPH #10-24 x 7/8 .....	4
51	323-6	Screw, HH 3/8-16 x 1 .....	8
52	103-0429-03	Wld, Bagger Mount.....	1
53	103-5612-03	Frame, Bracket (LH) .....	1
54	103-0399-03	Frame, Bracket (RH) .....	1
55	3290-357	Nut, Whizlock 3/8-16 .....	8
56	98-5975	Washer, Spring Disk 3/8.....	8

◆ Includes items 2,4,7,12,13,18 riveted together and Decal



# HOOD and BAG ASSEMBLY – LAZER Z 52”

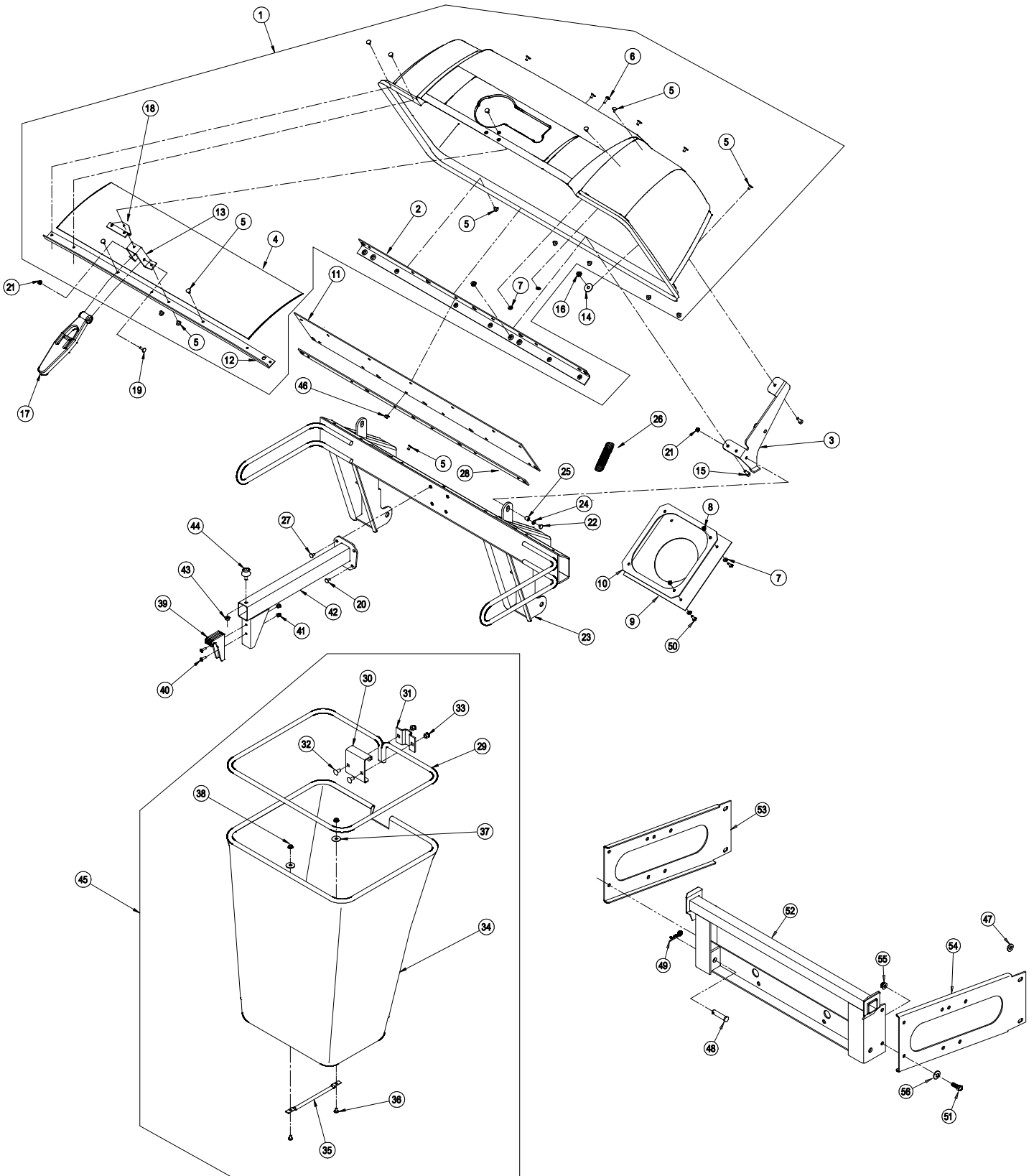

## HOOD and BAG ASSEMBLY – LAZER Z & LAZER Z XP (60" & 72")

Item	Part No.	Description	Qty.
1◆	103-0437	Asm, Hood.....	1
2	103-0382-03	Stiffener, Bagger Top.....	1
3	103-0430-03	Wld Hinge.....	2
4	103-0391	Reinforcement, Hood.....	2
5	103-0440	Screen, Bagger.....	1
6	114439	Rivet, Pop 3/16 x 1/2 .....	55
7	1-803075	Screw, Truss HD #10-24 x 3/4.....	5
8	3256-61	Washer, 216 x .750 x .049 .....	23
9	3296-2	Nut, Nyloc #10-24.....	8
10	103-0439	Seal, Tube .....	1
11	103-0378	Clamp, Seal.....	2
12	103-0451	Seal, Hinge.....	1
13	103-0452-03	Plate, Backing.....	1
14	103-0380-03	Support, Screen.....	1
15	103-0379	Bracket, Mount .....	2
16	321-4	Screw, HH 1/4-20 x 3/4.....	10
17	32128-33	Nut, Whizlock 1/4-20.....	10
18	1-653403	Latch .....	2
19	103-0376	Plate, Latch Reinforcement.....	2
20	321-11	Screw, HH 1/4-20 x 2.....	2
21	103-5124-03	Wld, Bag Support .....	2
22	3296-42	Nut, Nyloc 1/4-20.....	4
23	321-6	Screw, HH 1/4-20 x 1.....	2
24	103-4735-03	Wld, Bagger Upright .....	1
25	3256-2	Washer, 1/4 Std.....	4
26	1-633545	Spacer.....	2
27	1-653544	Spring.....	2
28	322-3	Screw, HH 5/16-18 x 3/4.....	4
29	1-653529-03	Frame, Bag.....	1
30	114973-03	Hanger, Bag .....	1
31	114974-03	Clamp.....	1

Item	Part No.	Description	Qty.
32	3230-1	Bolt, Carriage 5/16-18 x 3/4.....	2
33	3296-29	Nut, Nyloc 5/16-18.....	2
34	103-0431	Bag, Cloth .....	1
35	1-653566	Handle, Bag .....	1
36	3229-1	Bolt, Carriage 1/4-20 x 3/4.....	2
37	1-653036	Washer, .344 x 1.75 x .062 Pltd.....	2
38	3296-42	Nut, Nyloc 1/4-20.....	2
39	1-653404	Catch.....	1
40	3290-500	Screw, PPH #10-24 x 5/8 .....	2
41	3290-148	Nut, Whizlock #10-24 .....	2
42	1-806005	Hairpin.....	2
43	32128-33	Nut, Whizlock 1/4-20 .....	1
44	1-523420	Bumper .....	1
45	103-0429-03	Wld, Bagger Mount.....	1
46	103-5612-03	Bracket, Frame LH (LZ).....	1
47	103-0399-03	Bracket, Frame RH (LZ) .....	1
48	3290-357	Nut, Whizlock 3/8-16 (LZ).....	8
	3290-357	Nut, Whizlock 3/8-16 (XP) .....	14
49	98-5975	Washer, Spring Disk 3/8 (LZ) .....	8
	98-5975	Washer, Spring Disk 3/8 (XP).....	14
50	323-6	Screw HH 3/8-16 x 1 (LZ).....	8
	323-6	Screw HH 3/8-16 x 1 (XP) .....	14
51	283-69	Clevis Pin .....	2
52	103-0435	Asm, Bag.....	1
53	103-2975-03	Plate, Bagger Mount (XP).....	2
54	103-1155-03	Spacer (XP).....	2
55	3274-55	Screw, HSBH 5/16-18 x 3/4.....	4
56	3250-27	Screw, PPH #10-24 x 7/8 .....	4
57	32153-1	Nut, Side Lock #10-24 .....	5
58	71-9310	Spacer (LZ).....	6

◆ Includes items 2,5,6,8,14,15,19 riveted together and Decal

# HOOD and BAG ASSEMBLY – LAZER Z & LAZER Z XP (60" & 72")

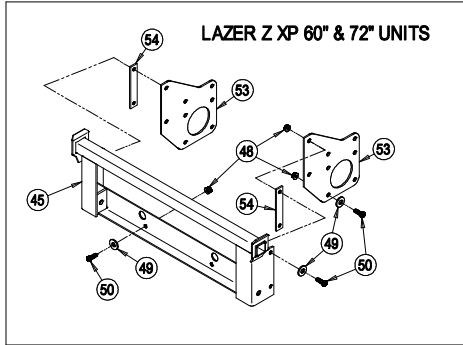
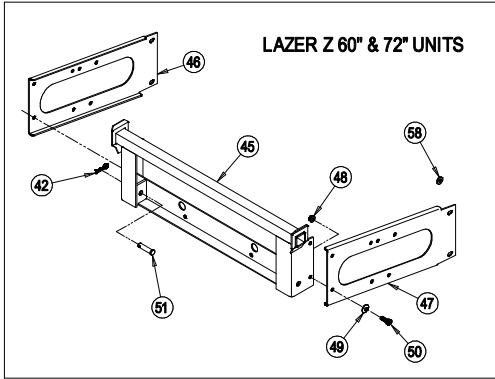
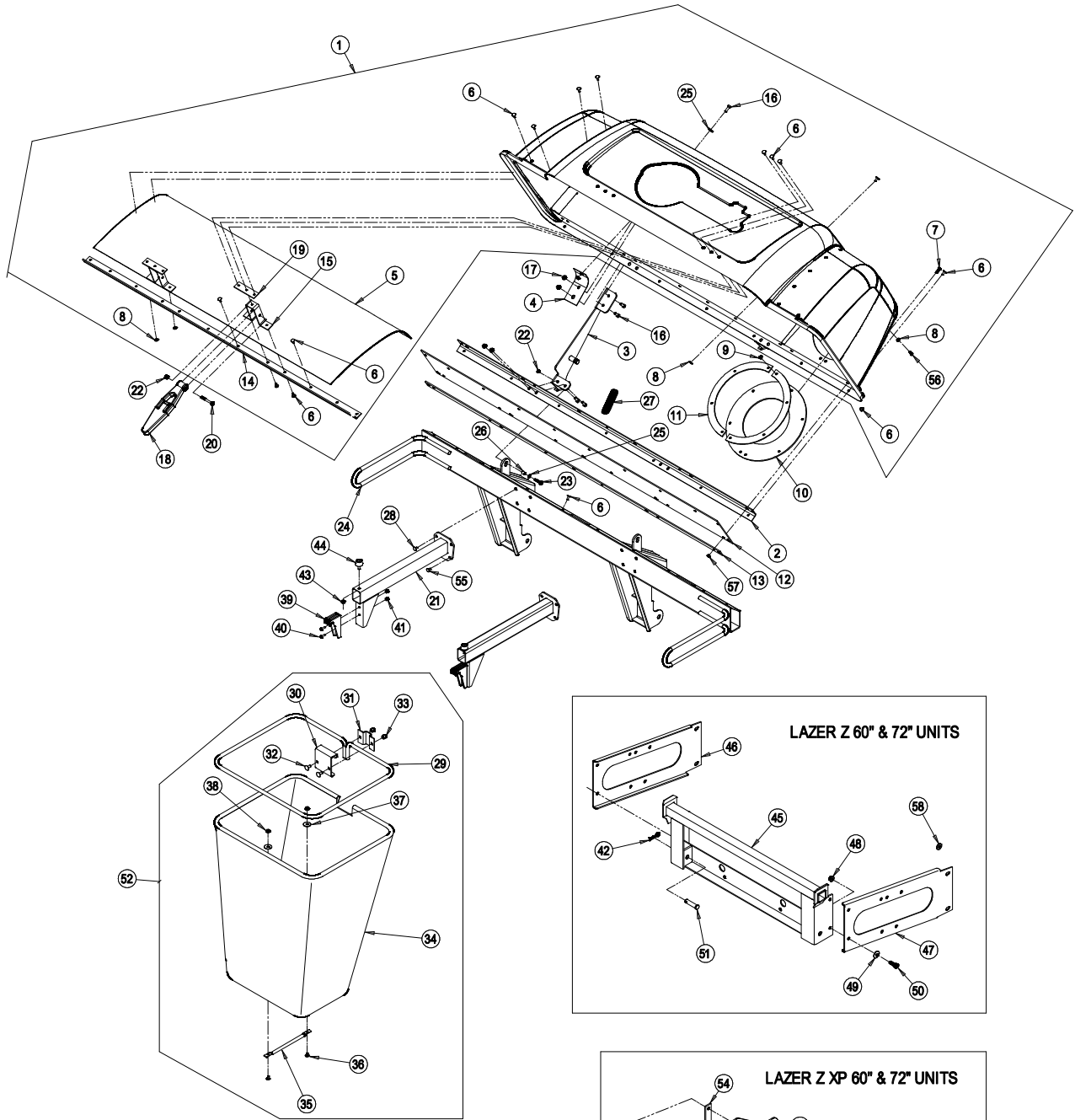

## WEIGHT and BELT DRIVE COMPONENTS

Ref. No.	Part No.	Description	LAZER			LAZER XP	
			52" 103-2997+	60"	72"	60"	72"
1	103-0453	Pin, Chute Pivot	1	1	1	1	1
2	1-806003	Hairpin, Cotter	1	1	1	1	1
3	103-2792	Sheave, Jackshaft LZUV 60		1		1	
	103-2796	Sheave, Jackshaft LZUV 72			1		1
	103-2797	Sheave, Jackshaft, LZUV 52	1				
4	1-653438	Belt, Blower Drive 52	1				
	103-0866	Belt, Blower Drive 60		1		1	
	103-0867	Belt, Blower Drive 72			1		1
5●	103-0899	Weight, 70lb w/ 1.5" bracket		1			
	103-0900	Weight, 70lb w/ 2.0" bracket		1			
	103-0901	Weight, 43lb w/ 1.5" bracket	1				
	103-0902	Weight, 43lb w/ 2.0" bracket	1		2	2	2
6	103-2180-01	Wld, Weight Bracket 2.0	1	1	2	2	2
	103-2181-01	Wld, Weight Bracket 1.5	1	1			
7	283-69	Pin, Clevis	2	2	2	2	2
8	1-806005	Hairpin, Cotter	2	2	2	2	2
9	3290-357	Nut, Whizlock 3/8-16	4	4	4	4	4
10	103-2500	Screw, Sq Head 3/8-16 x 2 1/2	4		4	4	4
	103-2189	Screw, Sq Head 3/8-16 x 4		4			
11	103-1425-03	Plate, Weight	4	4	4	4	4
12	322-9	Screw, HH 5/16 -18 x 1 3/4	4	4	4	4	4
13	3256-23	Washer, 5/16 SAE	4	4	4	4	4
14	32128-20	Nut, Whizlock 5/16-18	6	4	4	4	4
15	103-1028	Stud, Belt Shield		1	1	1	1
16	1-603610	Washer, Spring Disc 7/16		2		2	
17	1-633545	Spacer, Grommet		1		1	
18	103-1499	Support, Belt Cover	2				
19	1-323385	Knob	2				
20	3230-1	Screw, HH 5/16-18 x 3/4	2				
21	103-0734	Belt Cover 52"	1				
	103-0735	Belt Cover 60"		1		1	
	103-0736	Belt Cover 72"			1		1
22*	1-543610	Washer, 1/4	2	2			
23*	323-49	Bolt, Tap 3/8-16 x 3 1/4	2	2			
24	103-2187	Knob	2	2	2	2	2
25	3256-24	Washer	2	2	2	2	2
26	103-2188	Spring	2	2	2	2	2
27	103-1279	Plug	1	1	1	1	1
28	103-5856-01	Plate, Weight Mounting	2	2	2	2	2
29	103-5866	Asm, Weight Plate W/Decals	1	1	1	1	1
30	9335124	Hairpin, Cotter	2	2	2	2	2
31◇	103-5865	Template, Drill	1	1	1	1	1

✚ Completing kit assembly for Lazer Z 52".

\* Items not shown. Used to mount the bagger mount to the rear of units with S/N less than 190,000.

● Includes items 6, 9, 10, 24, 25, 26, weight and decal.

◇ Item not shown. Use to drill holes for front frame weights.

**ADAPTER KIT 103-1369:** For 52" Lazer Z models before serial number 260,000.

Part No.	Description	Qty
1-652375-01	Discharge Chute	1
1-805517	Washer 2.25 OD	1

# WEIGHT and BELT DRIVE COMPONENTS

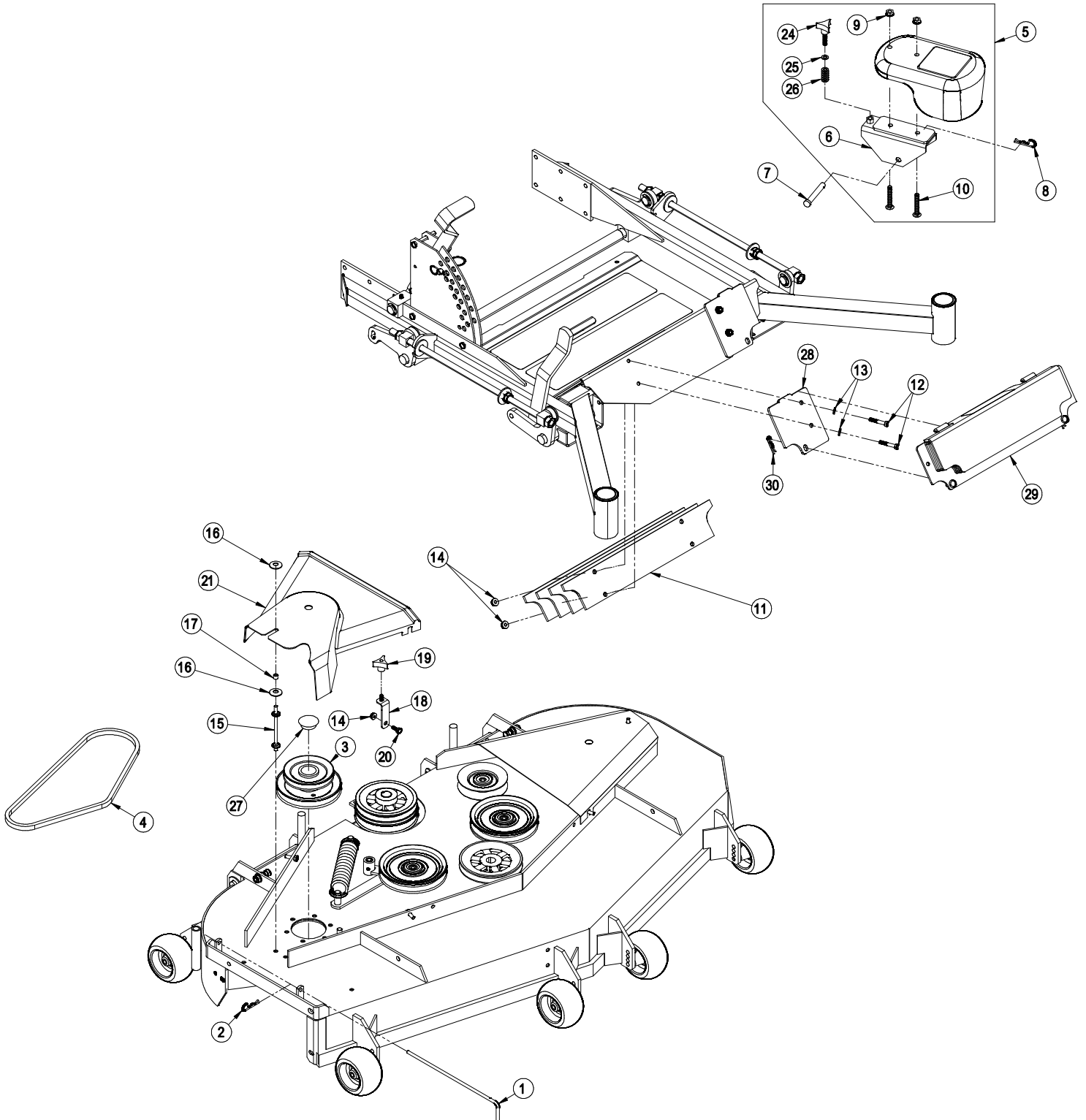

# DECALS

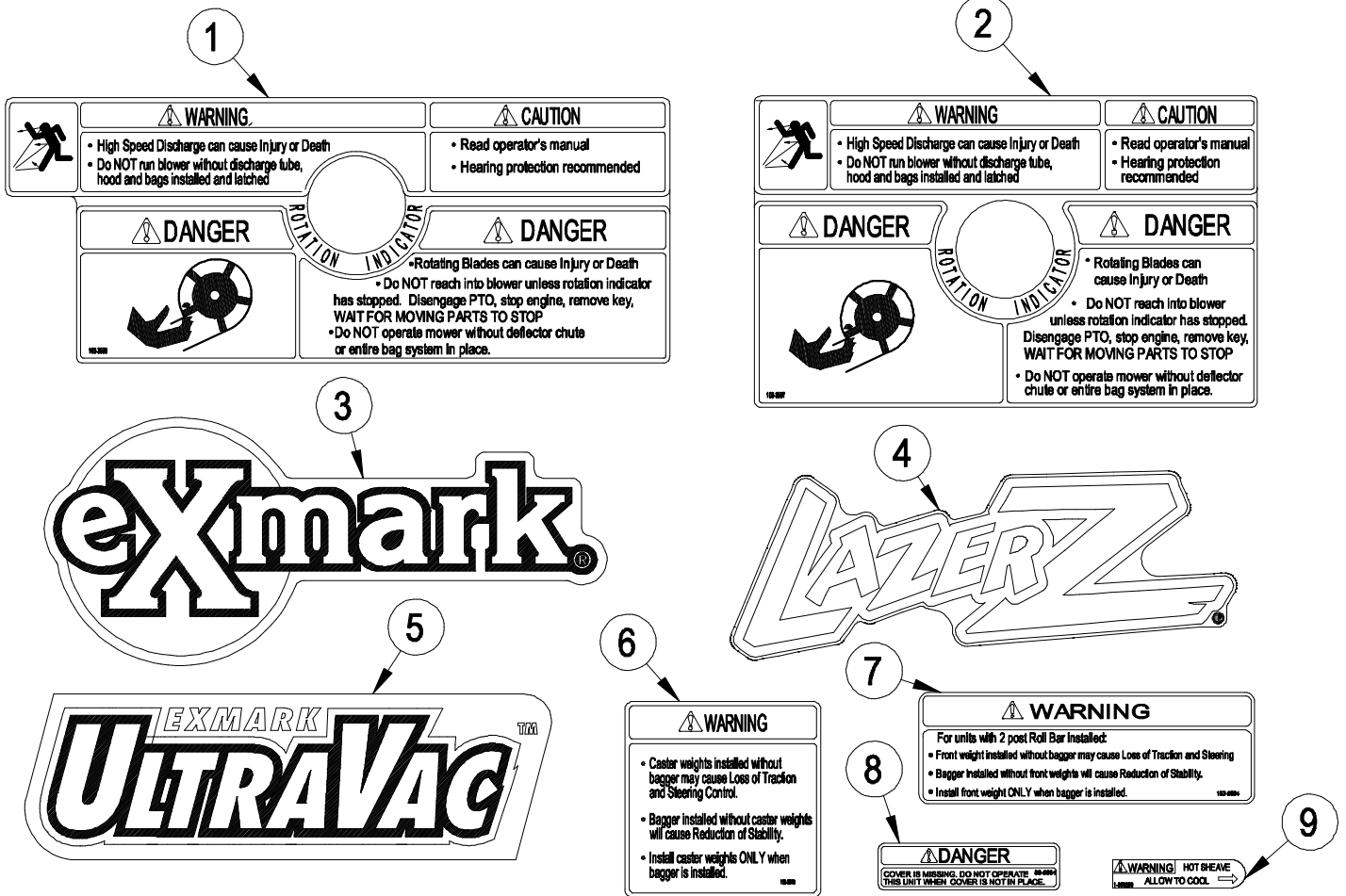

Item	Part No.	Description	Qty.
1	103-3508	Decal, Warning (52).....	1
2	103-3507	Decal, Warning (60 & 72).....	1
3	1-653546	Decal, Exmark (52).....	1
	103-0438	Decal, Exmark (60 & 72).....	1
4	103-3113	Decal, Lazer .....	1

Item	Part No.	Description	Qty.
5	1-653557	Decal, Ultra Vac .....	1
6	103-0878	Decal, Caster Weights.....	3
7	103-5894	Decal, Front Weight.....	1
8	98-5954	Decal, Missing Cover.....	1
9	1-653558	Decal, Hot Sheave .....	1



**SEE EXMARK'S COMPLETE  
LINE OF PRODUCTS FOR TURF CARE**

**LAZER Z<sup>®</sup>**

**LAZER Z<sup>®</sup> HP**

**LAZER Z<sup>®</sup> XP**

**LAZER Z<sup>®</sup> CT**

**TURF RANGER<sup>®</sup>**

**VIKING HYDRO**

**TURF TRACER<sup>®</sup>**

**TURF TRACER<sup>®</sup> HP**

**METRO<sup>®</sup>**

**METRO<sup>®</sup> HP**

**ULTRA VAC<sup>™</sup>**

**ULTRA VAC<sup>™</sup> QDS**

**GRASS CATCHER**

**MICRO-MULCH<sup>™</sup> ACCESSORY**

**SELF STEERING SULKY**

©1997 - 2003  
EXMARK MFG. CO. INC.  
INDUSTRIAL PARK BOX 808  
BEATRICE, NE 68310  
ALL RIGHTS RESERVED

PART NO. 103-5878  
(402) 223-6300  
FAX (402) 223-5489  
PRINTED IN U.S.A.

