

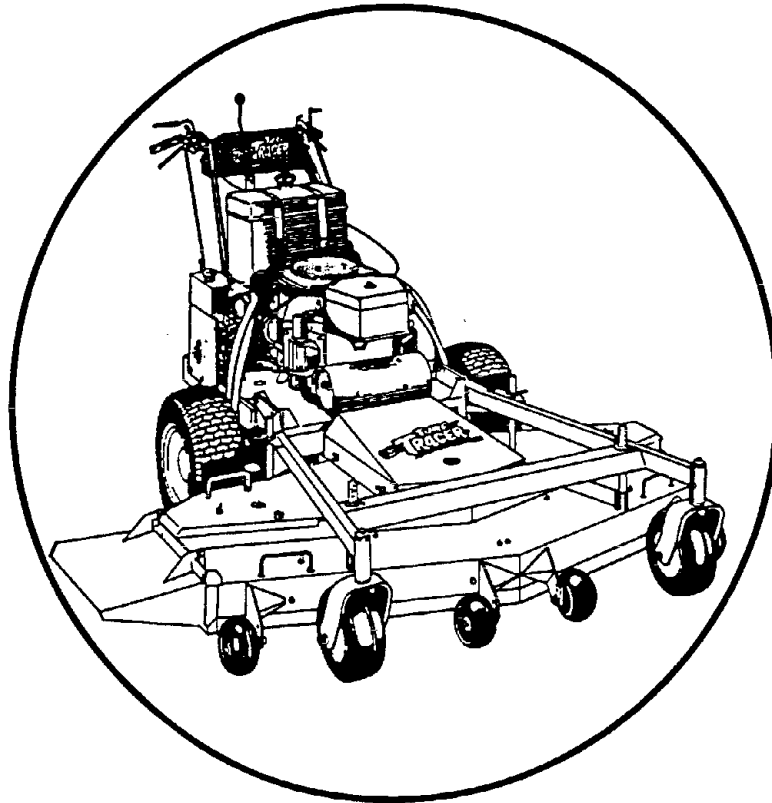

For Serial Nos.  
130,000 and Higher

# TURF TRACER HYDRO



## Parts Manual

**CONGRATULATIONS** on the purchase of your new Exmark mower. This product has been carefully designed and manufactured to give you a maximum amount of dependability and years of trouble-free operation.

If additional information is needed, or should you require trained mechanic service, contact your authorized Exmark equipment dealer or distributor.

If you need to order replacement parts from your dealer, always give the model number and serial number of your mower as well as the part number, description and quantity of the part needed.

The Serial No. plate is located on the top front engine frame on the right hand side of the machine and for the deck is on front support pin gusset on right hand side of deck.

For ease of ordering and reference, we suggest that you record the information requested in the following identification table.

Tractor Model No. \_\_\_\_\_

Tractor Serial No. \_\_\_\_\_

Deck Model No. \_\_\_\_\_

Deck Serial No. \_\_\_\_\_

Date Purchased \_\_\_\_\_

Purchased From \_\_\_\_\_

Paste Label From  
Literature Packet Here

# EXMARK PARTS PLUS® PROGRAM

EFFECTIVE DATE: September 1, 1995

## Program

If your Exmark dealer does not have the Exmark part in stock, Exmark will get the parts to the dealer the next business day or the part will be FREE\* Guaranteed!!

## *How the Program Works*

1. If dealer does not have part in stock for a "down" unit at the time of request by customer, the dealer contacts his distributor by 1:00 p.m., local time, and requests Exmark Parts Plus® shipment of six (6) line items or less.
2. Distributor ships part(s) to dealer or customer, as requested by dealer, same day, overnight UPS. Distributor bills dealer for part and freight charges where applicable.
3. If distributor does not have the part(s) in stock to satisfy Exmark Parts Plus® order, he contacts Exmark by 3:00 p.m., central time, with an Exmark Parts Plus® order of six (6) line items or less.
4. If order is received by 3:00 p.m. central time, Exmark ships part(s) direct to dealer or customer, as requested by distributor, same day, overnight UPS. Exmark bills the distributor for parts and shipping charges, where applicable.
5. The customer pays for the part and freight if it is shipped under the Exmark Parts Plus® and if it arrive in accordance to the program.
6. Who pays for the part and freight if it fails to arrive overnight in accordance to the program?
  - A. Under any circumstance the customer does not pay.
  - B. If the part does not arrive overnight due to:
    1. The dealer not submitting the Exmark Parts Plus® order to his Exmark distributor by 1:00 p.m., the dealer pays for the part and freight.
    2. The Distributor being unable to ship the part the same day or not submitting the Exmark Parts Plus® order to Exmark by 3:00 p.m., central time, the Distributor pays for the part and freight.
    3. Exmark being unable to ship the part and the Exmark parts order is received by 3:00 p.m., central time, Exmark pays for the part and freight.
    4. If the part does not arrive overnight due to the shipper (UPS), the shipper pays for the freight and Exmark pays for the part.

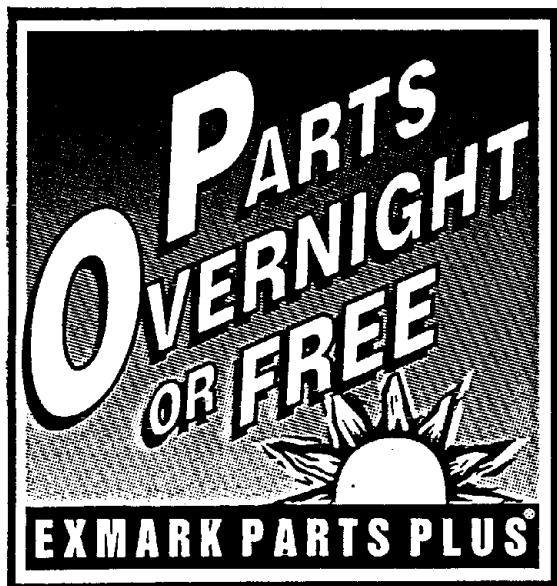

**The following restrictions apply** -- The Exmark Parts Plus® Program is available only through participating Exmark Dealers and applies only to orders submitted on this program Monday through Thursday. UPS has initiated a Saturday delivery program to many areas of the continental United States and can be requested for an overnight shipment on Friday to be delivered Saturday. The next day air charge, plus the Saturday delivery fee will be the responsibility of the purchaser. Exmark Mfg. will assume no responsibility for Saturday delivery shipments. To qualify, all Exmark Parts Plus® orders must be received by Exmark by 3:00 p.m., central time. Orders must be six (6) line items or less. Exclusions from the Exmark Parts Plus® Program are: Any wholegood or accessory in its entirety, engines and engine replacement parts, 5-speed Peerless transmissions and 5-speed transaxles, hydraulic or hydrostatic wheel motors, cutter decks and engine decks or any item exceeding United Parcel Service size and weight restrictions.

Due to UPS restrictions, aerosol spray paint is considered a hazardous material and cannot be shipped via UPS next day or Second Day Air.

Exmark Manufacturing stocks a limited supply of parts for transaxles, pumps and wheel motors. These parts can be ordered for Next Day Air shipment but will not be guaranteed per the Parts Plus Program.



**READ OPERATOR'S MANUAL BEFORE  
OPERATING OR SERVICING EXMARK EQUIPMENT.**

## **TABLE OF CONTENTS**

<b><u>Description</u></b>	<b><u>Page</u></b>
Decals .....	9
Electrical Diagrams .....	13
Electrical Group.....	12
Engine Deck Group.....	6 - 7
52" Mower Deck .....	2 - 3
Fuel Group .....	10
Handles & Controls .....	8
Hydraulics Group .....	11
60" Mower Deck .....	4 - 5



## 52" MOWER DECK

Ref. No.	Part No.	Description	Qty. Req'd.	Ref. No.	Part No.	Description	Qty. Req'd.
1	604960	Support, deck 612092 w/ bushings & decals .....	1	39	809035	Bolt, taptite 3/8-16 x 1.....	18
2	800292	Capscrew, 3/8-16 x 1.....	11	40*	612155	Deck, 612153 with decals, support rods & dogleg baffle...	1
3⇨	303327	Washer, disc spring 3/8.....	20	41	602571	Chute, discharge.....	1
4⇨	809007	Nut, whizlock 3/8-16 .....	30	42	800273	Capscrew, 5/16-18 x 1.....	2
5	806006	Hairpin, 5/8 .....	2	43	804256	Nut, nylock 5/16-18.....	2
6	303164	Spacer, blade driver.....	2	44	800270	Capscrew, 5/16-18 x 5/8.....	6
7	806007	Hairpin, 7/8 .....	2	45	303516	Pulley, V-Idler .....	2
8	513338	Washer .....	2	46	809001	Nut, whizlock 5/16-18 .....	6
9	513336	Bushing, deck support.....	2	47	603504	Spacer, tube .....	1
10	808507	Ring, retaining (external) .....	2	48	603581	Sheave, mower drive.....	1
11	805006	Washer, lock 3/8 hvy spring ...	2	49	603413	Spring, extension.....	1
12⇨	373034	Washer, pivot.....	13	50	603497	Pulley, idler .....	1
13	811001	Zerk, 1/8 NPT (straight).....	2	51	803016	Screw, whizlock 3/8-16 x 1 .....	2
14	303514	Bearing, flange thrust.....	4	52	804257	Nut, nylock 3/8-16.....	2
15	522143	Fork, caster.....	2	53	805260	Washer, 3/8 .....	2
16	800334	Capscrew, 1/2-13 x 6.....	2	54	513034	Bearing, pivot.....	4
17	805008	Washer, lock 1/2.....	2	55	602604	Idler arm assy w/bearings.....	1
18	804509	Nut, 1/2-13.....	2		602591	Arm, deck idler.....	1
19	513547	Spacer, front caster .....	2	56	603384	Bushing, idler pivot .....	2
20	513648	Tire/wheel assy, 9 x 3.50-4.....	2	57	602865	Idler arm, w/bearings deck drive .....	1
	513807	Wheel.....	2		602867	Arm, deck drive idler.....	1
	513808	Tire 9 x 3.50-4.....	2	58	811008	Zerk, 1/4-28 (90°) .....	2
	513809	Bearing .....	2	59	800297	Capscrew, 3/8-16 x 2-1/4 .....	4
	513810	Bushing.....	4	60	603540	Link, rear deck support.....	2
21	612047	Cover with decal, (deck drive belt) .....	1	61	803031	Nut, torque 3/8-24.....	2
22	602545	Cover, deck.....	2	62	603299	Roller, anti scalp .....	6
23	603576	Belt, blade drive .....	1	63	800807	Capscrew, 3/8-16 x 4.....	6
24	811006	Zerk, 1/4-28 (straight).....	3	64	603602	Bushing, roller.....	6
25	804510	Nut, 5/8-18 UNF.....	3	65	603620	Bracket, spring anchor.....	1
26	513208	Spring, disk.....	6	66	800805	Capscrew, 3/8-16 x 3 1/2.....	2
27	513207	Sheave, blade drive .....	3	67	603414	Spring, extension.....	1
28	303543	Bearing, ball .....	6	68	543678	Wingnut, nylock .....	4
29	413314	Housing, bearing.....	3	69	602913	Baffle.....	1
30	513188	Spacer, bearing .....	3	70	614154	Housing, cutter complete (center) .....	1
31	513193	Seal, dust.....	3		614145	Housing, cutter complete (outer) .....	2
32	808506	Snap ring, 2.59 x 08TK.....	3	71⇨	805259	Washer, 3/8 SAE .....	9
33	807006	Key, woodruff #61.....	4	72	603001	Rod, deck support .....	2
34	613106	Spindle, outer blade .....	2	73	806332	Roll pin, 1/4 x 1-1/2.....	2
35	613107	Spindle, center blade .....	1	74	613098	Pulley, flat idler .....	1
36	633482	Blade, 18" diameter .....	3	75⇨	603805	Idler.....	1
	633485	Blade, low lift.....	3	76⇨	513791	Bushing.....	1
+	633484	Blade, mulching .....	3	77⇨	603494	Spacer .....	1
37	303542	O-ring.....	3	78⇨	800302	Capscrew, 3/8-16 x 4.....	1
38	800340	Capscrew, 5/8-11 x 1 (RH).....	3				

⇨ These parts are available in an Idler Pulley Kit (Part No. 601806). Each kit contains one item each of the referenced item number.

+ Requires installation of Micro-Mulch accessory for proper mulching. Mulch kit P/N MK523.  
Exmark red touch up spray paint - P/N 850337

\* Deck weldmt does include welded in flow control baffles

# 60" MOWER DECK

Torque to  
30-35 ft.-lbs.

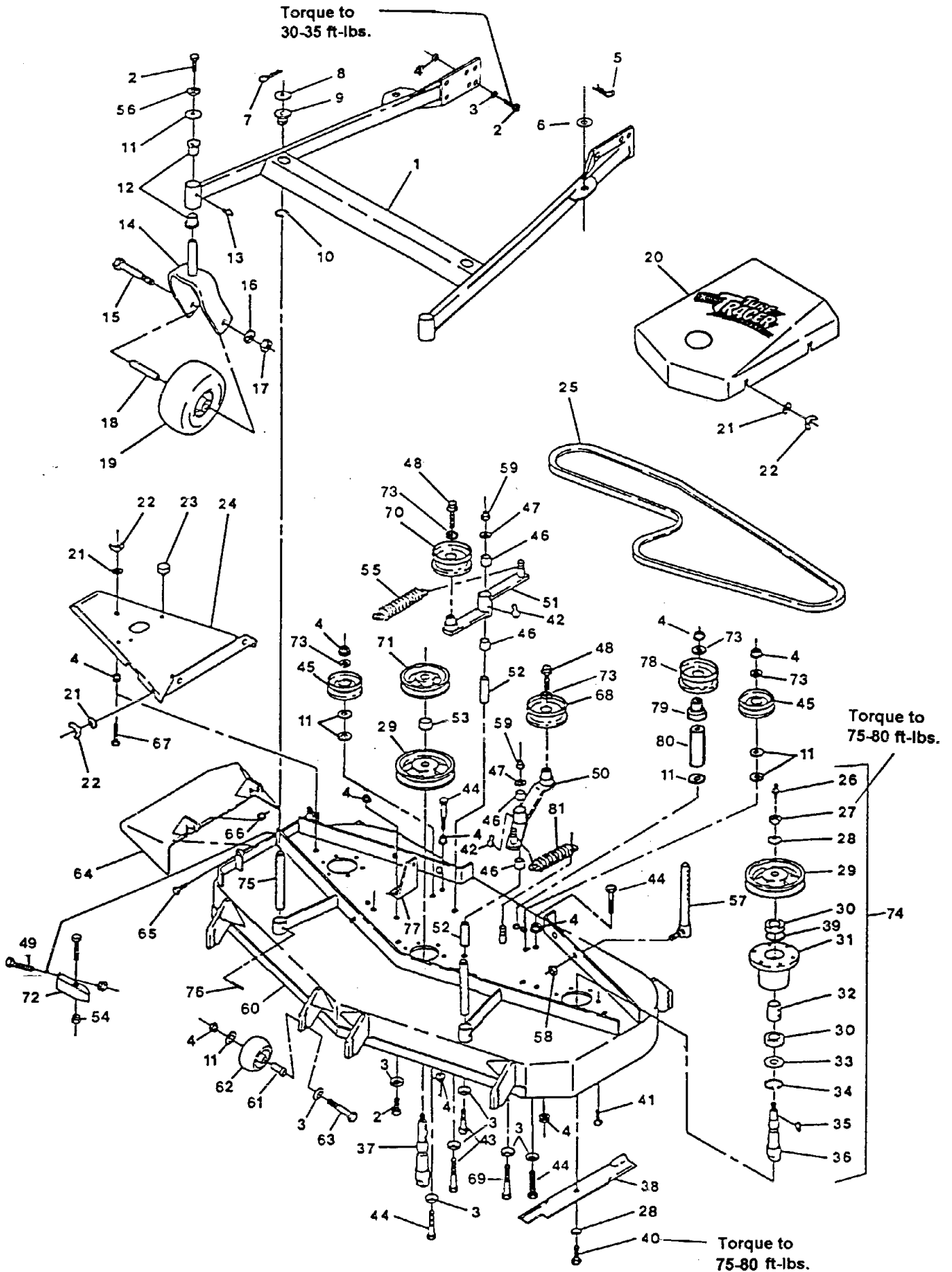

Torque to  
75-80 ft.-lbs.

Torque to  
75-80 ft.-lbs.

## 60" MOWER DECK

Ref. No.	Part No.	Description	Qty. Req'd.	Ref. No.	Part No.	Description	Qty. Req'd.
1	604847	Support, deck 612094 w/ bushings & decals.....	1	40	800340	Capscrew, 5/8-11 x 1 (RH).....	3
2	800292	Capscrew, 3/8-16 x 1.....	9	41	809035	Bolt, taptite 3/8-16 x 1.....	18
3	303327	Washer, disc spring 3/8.....	20	42	811008	Zerk, 1/4-28 (90°).....	2
4	809007	Nut, whizlock 3/8-16.....	30	43	800805	Capscrew, 3/8-16 x 3.5.....	2
5	806006	Hairpin, 5/8.....	2	44	800297	Capscrew, 3/8-16 x 2-1/4.....	4
6	303164	Spacer, blade driver.....	2	45	303516	Pulley, V-idler.....	2
7	806007	Hairpin, 7/8.....	2	46	513034	Bearing, pivot.....	4
8	513338	Washer.....	2	47	805260	Washer, 3/8 std flat.....	2
9	513336	Bushing, deck support.....	2	48	803016	Bolt, whizlock 3/8-16 x 1.....	2
10	808507	Ring, retaining (external).....	2	49	800270	Capscrew, 5/16-18 x 5/8.....	6
11	373034	Washer, pivot.....	13	50	602867	Arm, deck drive idler.....	1
12	303514	Bearing, flange thrust.....	4		602865	Idler arm assy, deck drive (with bearings).....	1
13	811001	Zerk, 1/8 NPT (straight).....	2	51	602591	Arm, deck idler.....	1
14	522143	Fork, caster.....	2		602604	Idler arm, w/bearings.....	1
15	800334	Capscrew, 1/2-13 x 6.....	2	52	603384	Bushing, idler pivot.....	2
16	805008	Washer, lock 1/2.....	2	53	603504	Spacer, tube.....	1
17	804509	Nut, 1/2-13.....	2	54	809001	Nut, whizlock 5/16-18.....	6
18	513547	Spacer, front caster.....	2	55	603413	Spring, extension.....	1
19	513648	Tire/whl assy, 9 x 3.50-4.....	2	56	805006	Washer, lock 3/8 (hvy spring)..	2
	513807	Wheel.....	2	57	603540	Link, rear deck support.....	2
	513808	Tire 9 x 3.50-4.....	2	58	803031	Nut, torque 3/8-24.....	2
	513809	Bearing.....	2	59	804257	Nut, nylock 3/8-16.....	2
	513810	Bushing.....	4	60*	612149	Deck, 612120 with decals, support rods & dogleg baffle ...	1
20	612048	Cover w/decals (deck drv belt).	1	61	603602	Bushing, roller.....	6
21	805259	Washer, 3/8.....	10	62	603299	Roller, anti scalp.....	6
22	543678	Wingnut, nylon insert.....	10	63	800807	Capscrew, 3/8-16 x 4 (Gr 8)....	6
23	513291	Bumper, seat.....	2	64	542606	Chute, discharge.....	1
24	542588	Cover, deck.....	2	65	800273	Capscrew, 5/16-18 x 1.....	2
25	603045	Belt, blade drive.....	1	66	804256	Nut, nylock 5/16-18.....	2
26	811006	Zerk, 1/4-28 (straight).....	3	67	800031	Tapbolt, 3/8-16 x 2 3/4.....	2
27	804510	Nut, 5/8-18 UNF.....	3	68	613098	Pulley, flat idler.....	1
28	513208	Washer, disc spring.....	6	69	800302	Capscrew, 3/8-16 x 4 (Gr 5)....	1
29	513207	Sheave, blade drive.....	3	70	603497	Pulley, idler.....	1
30	303543	Bearing, ball.....	6	71	613024	Sheave, mower drive.....	1
31	413314	Bearing, housing.....	3	72	602913	Baffle.....	1
32	513188	Spacer, bearing.....	3	73	805259	Washer, 3/8 SAE.....	5
33	513193	Seal, dust.....	3	74	614145	Cutter housing, (outer, cmplt)..	2
34	808506	Snap ring, 2.59 x 08TK.....	3		614146	Cutter housing, (cntr, cmplt) ...	1
35	807006	Key, woodruff 5/8 x 3/16.....	4	75	603001	Rod, deck support.....	2
36	613106	Spindle, outer blade.....	2	76	806332	Roll pin, 1/4 x 1-1/2.....	2
37	613107	Spindle, center blade.....	1	77	603620	Bracket, spring anchor.....	1
38	633483	Blade, 20 1/2" diameter.....	3	78	603805	Idler.....	1
	613111	Blade, low lift.....	3	79	513791	Bushing.....	1
‡	613112	Blade, mulching.....	3	80	603494	Spacer.....	1
39	303542	O-ring.....	3	81	603414	Spring, extension.....	1

◇ These parts are available in an Idler Pulley Kit (Part No. 601806). Each kit contains one item each of the referenced item number.

‡ Requires installation of Micro-Mulch accessory for proper mulching. Mulch kit P/N MK603.  
Exmark red touch up spray paint - P/N 850337

\* Deck weldmt does include welded in flow control baffles

# ENGINE DECK GROUP

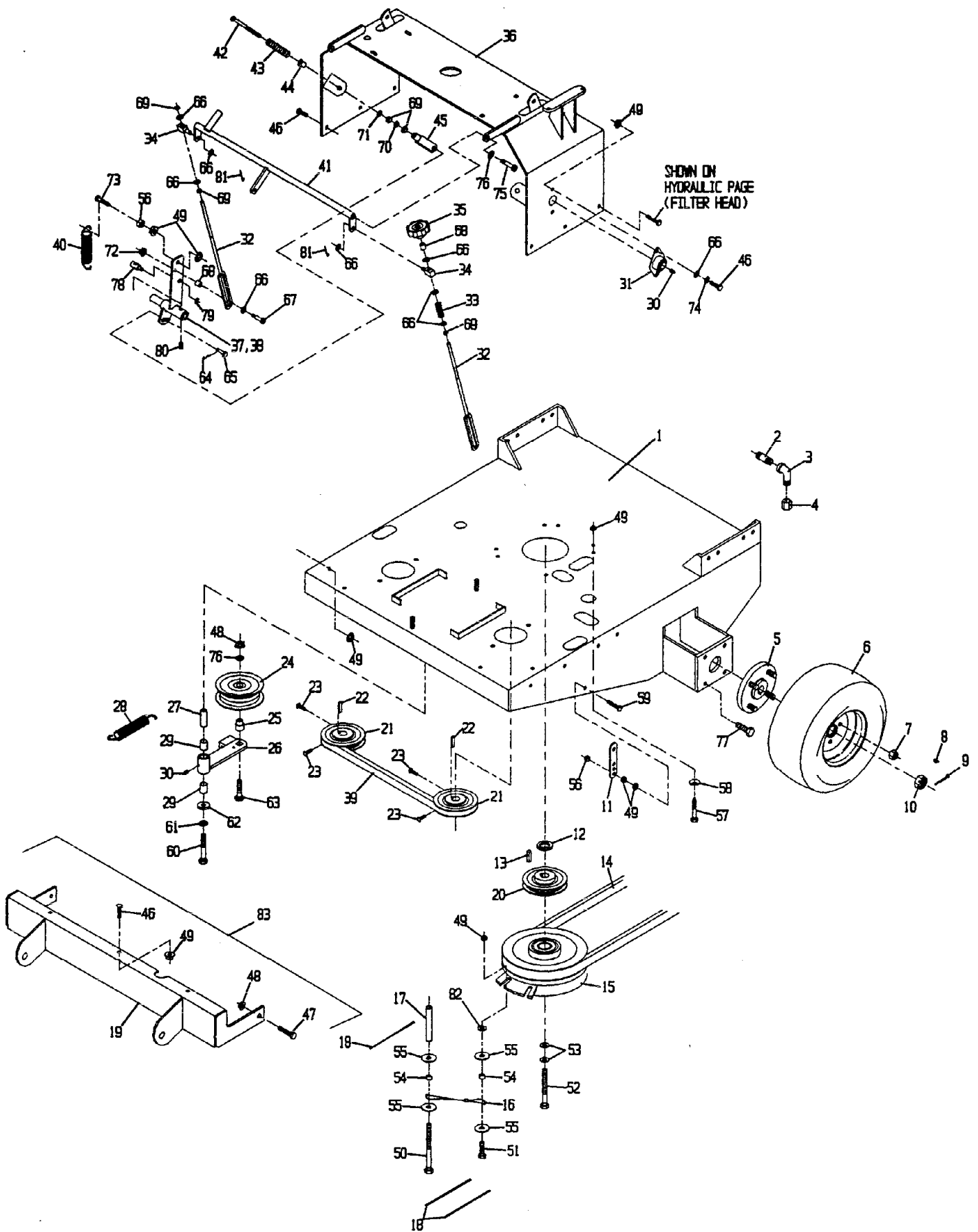



## ENGINE DECK GROUP

Ref. No.	Part No.	Description	Qty. Req'd.	Ref. No.	Part No.	Description	Qty. Req'd.
1	602944	Engine Deck Weldment.....	1	40	603693	Spring, extension .....	2
2*	543064	Pipe nipple.....	1	41	612173	Crank weldmt .....	1
3*	403124	Elbow, 90 street.....	1	42	603737	Bolt, neutral return.....	2
4*	543233	Cap, 3/8 NPT Hex .....	1	43	603807	Spring, neutral return .....	2
5◇	602997	Hub, 4 bolt.....	2	44	603735	Bushing, flanged.....	2
	613150	Stud .....	8	45	303105	Yoke, adjustable.....	2
6	603627	Tire and wheel assy .....	2	46	800271	Screw, 5/16-18 x 3/4 .....	13
	603763	Tire only.....	2	47	800292	Screw, 3/8-16 x 1 .....	2
	603715	Rim only .....	2	48	809007	Nut, 3/8-16 whizlock.....	3
7	513011	Nut, wheel .....	8	49	809001	Nut, 5/16-18 whizlock.....	24
8	807019	Key, woodruff 1" x 1/4" .....	2	50	800385	Screw, 5/16-18 x 4 1/2 .....	1
9	806800	Pin, cotter 9/64 X 1 1/2.....	2	51	800274	Screw, 5/16-18 x 1 .....	1
10	803040	Nut, 3/4-16-2B slotted hex.....	2	52▽	800819	Screw, 7/16-20 x 2 1/2 .....	1
11	613089	Anchor, spring .....	2	53	603610	Washer, spring disc .....	2
12	543214	Spacer, crankshaft .....	1	54	543007	Spacer, clutch anchor .....	2
13	807259	Key, 1/4 x 1/4 x 1.....	2	55	213069	Washer, 1 1/2" dia.....	4
14	611022	Kit, Belt/Shield(60").....	1	56	804256	Nut, nylock 5/16-18.....	5
	603306	Belt,deck drive(60") .....	1	57	800275	Screw, 5/16-18 x 1 1/2 .....	4
	611023	Kit, Belt/Shield(52").....	1	58	303334	Washer, 5/16 disc spring .....	4
	603306	Belt,deck drive(52") .....	1	59	800016	Bolt, tap 5/16-18 x 1 1/4 .....	2
15	614185	Clutch assy w/cable.....	1	60▽	800298	Screw, 3/8-16 x 2 1/2 .....	1
16	602974	Cable assy.....	1	61	805006	Washer, lock 3/8 heavy.....	1
17	323195	Standoff, clutch.....	1	62	373034	Washer, pivot.....	1
18	303287	Plastic tie, small.....	3	63	807517	Screw, 3/8-16 x 1 3/4 .....	1
19	602438	Hitch weldmt.....	1	64	806003	Hairpin, cotter.....	2
20●	603589	Sheave, 4 1/4 O.D.....	1	65	808280	Clevis pin.....	2
21	603778	Sheave, Pump.....	2	66	805257	Washer, 5/16.....	12
22	807272	Key, 5mm sq x 25mm.....	2	67▽	809057	Screw, 5/16 x 3/4sckt hd shldr	2
23▽	803050	Setscrew, 5/16-18 x 3/4.....	4	68	603903	Spacer.....	3
24	603843	Pulley, idler .....	1	69	804521	Nut 5/16-24 regular .....	7
25	603496	Bushing, idler.....	1	70	804758	Nut, 5/16-24 jam.....	2
26	602521	Idler arm w/bushings .....	1	71	805256	Washer, 1/4.....	2
	602458	Idler arm weldmt.....	1	72	809012	Nut, whizlock 1/4-20.....	2
27	603044	Bushing, idler pivot .....	1	73	800274	Screw, 5/16-18 x 1-1/4 .....	2
28	603402	Spring, extension.....	1	74	805005	Washer, lock 5/16 heavy.....	4
29	513034	Bearing, pivot .....	2	75▽	809056	Screw, 3/8 x 3/8 sckt hd shld ...	2
30	811006	Zerk, grease 1/4-20.....	3	76	805259	Washer, 3/8 SAE flat.....	3
31	633102	Bearing, flanged .....	2	77	803045	Screw, whizlock 3/8-16 x3/4 ...	8
32	412211	Rod, control arm.....	2	78	413227	Swivel, drive lever .....	2
33	323245	Spring .....	1	79	808520	Klipring .....	2
34	603676	Swivel .....	2	80▽	803022	Setscrew, 5/16-18 x 5/8 .....	2
35	413151	Knob, tracking .....	1	81	806753	Cotter pin.....	2
36	612165	Support, tank/handle .....	1	82	805258	Washer, 5/16.....	1
37	612160	Arm, control LH .....	1	83	601000	Hitch Kit, sulky .....	1
38	612162	Arm, control RH (not shown)..	1				
39	603809	Belt, hydro trans drive .....	1				

\* Use Teflon Pipe Sealant or equivalent on threads.

▽ Use (Part No. 840022) Pro-lock, nut type (.5 ml tube) on threads.

Exmark red touch up spray paint - P/N 850337

Exmark black touch up spray paint - Gloss black

◇ Use anti-seize on hub bore

● Install sheave with long end of hub up

# HANDLE AND CONTROLS

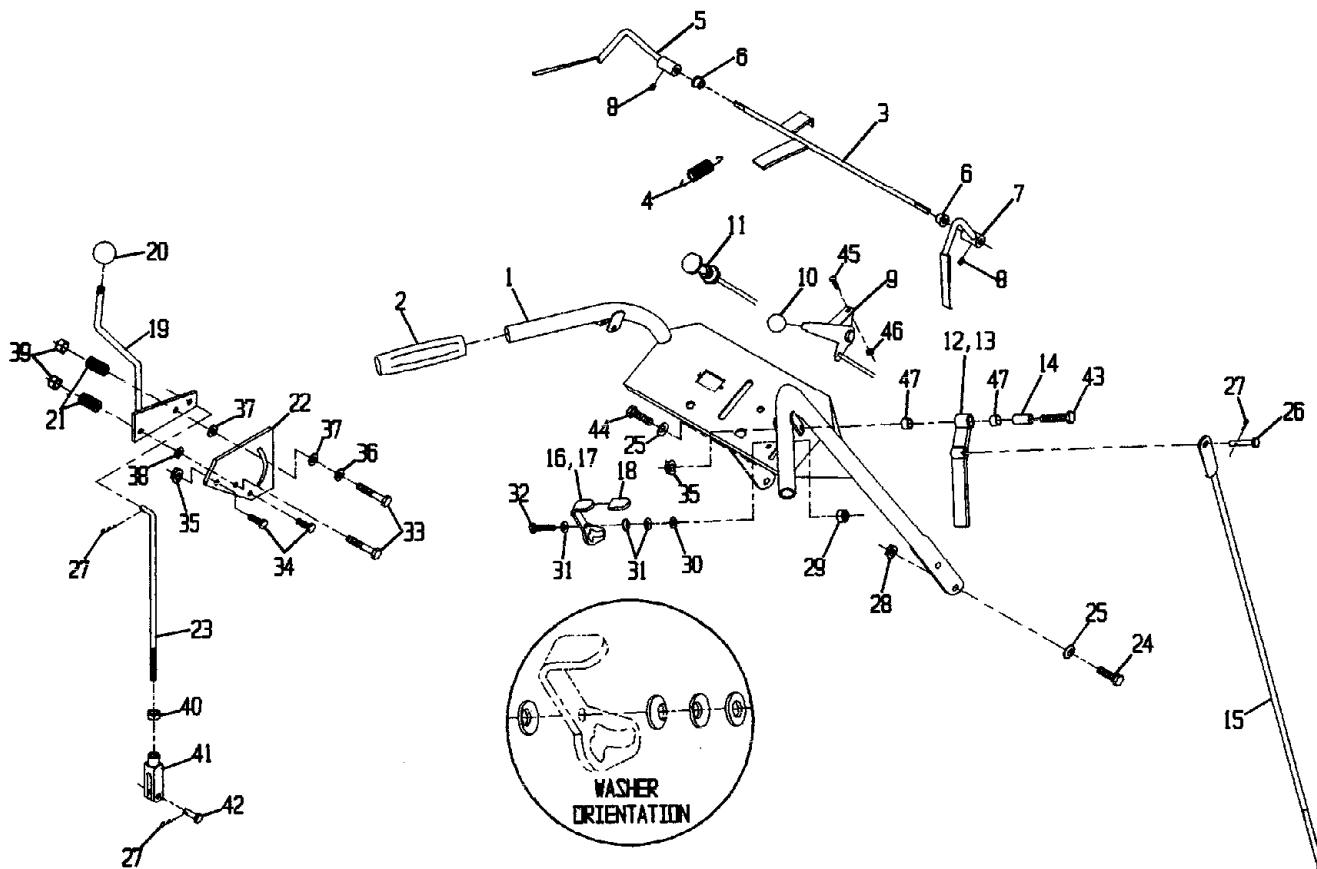

Ref. No.	Part No.	Description	Qty. Req'd.	Ref. No.	Part No.	Description	Qty. Req'd.
1	612182	Handle wldmnt, hydro .....	1	25	303327	Washer, spring disk .....	4
2	303097	Grip, handle .....	2	26	613055	Pin, clevis .....	2
3	612187	Rod wldmnt, OPC .....	1	27	806003	Hairpin cotter .....	4
4	303363	Spring .....	1	28	809007	Nut, whizlock 3/8-16 .....	4
5∇	412183	Lever wldmt, OPC Lh .....	1	29	804255	Nut, nylock 1/4-20 .....	2
6	303365	Bushing, nylon .....	2	30	805256	Washer, 1/4 std flat .....	2
7∇	412185	Lever weldmt, OPC Rh .....	1	31	303435	Washer, 1/4 disc spring .....	6
8◇	803322	Setscrew .....	2	32	800257	Screw, 1/4-20 x 1-3/4 .....	2
9	603199	Throttle control .....	1	33	800277	Screw, 5/16-18 x 2 .....	2
10	513592	Knob, red ball .....	1	34	800251	Screw, 1/4-20 x 5/8 .....	2
11	603336	Choke control push/pull .....	1	35	809012	Nut, whizlock 1/4-20 .....	4
12	412161	Drive lever RH (shown) .....	1	36	603716	Washer, friction .....	1
13	412159	Drive lever LH (not shown) .....	1	37	323244	Washer, friction .....	2
14	603749	Bushing, drive lever .....	2	38	805257	Washer, 5/16 flat .....	1
15	613189	Rod, drive lever .....	2	39	804256	Nut, nylock 5/16-18 .....	2
16	612168	Latch, thumb RH (shown)w/grip .....	1	40	804758	Nut, jam 5/16 .....	1
17	612167	Latch, thumb LH w/grip .....	1	41	303105	Yoke, adjustable .....	1
18	303019	Grip, vinyl latch .....	2	42	808280	Pin, clevis .....	1
19	602733	Lever, shifter .....	1	43	800256	Screw, 1/4-20 x 1-1/2 .....	2
20◇	603175	Knob, 1-3/8 .....	1	44	800293	Screw, 3/8-16 x 1-1/4 .....	1
21	323245	Spring, compression .....	2	45	807513	Screw, 10-24 x 1/2 .....	2
22	603730	Plate, shifter lever .....	1	46	804252	Nut, nylock 10-24 .....	2
23	603700	Rod, speed control .....	1	47	413152	Bearing .....	4
24	800292	Screw, 3/8-16 x 1 .....	3				

◇ Use Pro-Lock Nut Type (P/N 840022 .5 ml. Tube) on setscrews and on shifter knob threads

∇ Use Pro-Lock Retaining 1 (P/N 840023 .5cc Tube) on inside bore of OPC Hub

Exmark black touch up spray paint - Gloss black

# DECALS

**DANGER**

- USE EXTREME CAUTION WHEN OPERATING ON SLOPES
- NEVER ACROSS SLOPE - NEVER UP AND DOWN
- DO NOT OPERATE ON SLOPES GREATER THAN 20°
- WATCH FOR DITCHES, HOLES, ROCKS, RYSES, DIPS
- KEEP AWAY FROM DROP-OFFS AND STEEP BANKS
- LOOK BEHIND YOU BEFORE BACKING
- DRIVE SLOWER ON SLOPES
- CHECK BLADES SLOWLY
- DO NOT MOW WET SLOPES
- AVOID SUDDEN STARTS

323525

NO 20°

• KEEP ALL PEOPLE OUT OF AREA WHEN MOWING

• THROWING OBJECTS OR BLADE CONTACT CAN CAUSE SERIOUS INJURY OR DEATH

• DO NOT OPERATE IN AN ENCLOSED AREA

• ENGINES PRODUCE CARBON MONOXIDE WHICH IS AN ODORLESS DEADLY POISON



**WARNING**

DO NOT OPERATE WITHOUT DISCHARGE DEFLECTION OR ENTIRE GRASS COLLECTION SYSTEM IN PLACE. DO NOT REMOVE GRASS CATCHER UNTIL BLADES HAVE STOPPED.

**WARNING**

DISCHARGE BLADE CLUTCH MUST BE OFF BEFORE AND REMOVE KEY BEFORE LEAVING MOWER. SERVICING OR REPAIRING DECK.

CUTTING HEIGHT ADJUSTMENT

1.5 IN	CUTTING HEIGHT
2.0 IN	HEIGHT
2.5 IN	HEIGHT
3.0 IN	HEIGHT
3.5 IN	HEIGHT
4.0 IN	HEIGHT
4.5 IN	HEIGHT

ANTI-SCALP ROLLER ADJUSTMENT

FOR MAXIMUM DECK ROTATION, PLACE ROLLERS IN POSITIONS SHOWN.

1.0	IN
1.5	IN
2.0	IN
2.5	IN

ROLLERS SHOULD MAINTAIN 1/4" (6.35 MM) CLEARANCE TO GRASS. DO NOT ADJUST ROLLERS TO SUPPORT MOWER DECK.

6  
5  
4  
3  
2  
1  
N

**CAUTION**

ALLOW ENGINE TO COOL FOR 2 MINUTES BEFORE REFUELING

FAST

SLOW

THROTTLE

**WARNING**

OPEN BELT DRIVE! STOP ENGINE BEFORE REACHING UNDERNEATH

NEUTRAL LOCK

↓

**CAUTION**

MUFFLER AND SHIELDS MAY EXCEED 150° F (327° F)

OFF ON

START

**WARNING**

BATTERY CONTAINS SULFURIC ACID, AVOID CONTACT AND ALWAYS SHIELD EYES, FACE, SKIN AND CLOTHING FROM BATTERY, CIGARETTES, FLAMES OR SPARKS. COULD CAUSE BATTERY TO EXPLODE. DO NOT CHARGE OR USE BOOSTER CABLES OR ADJUST POST CONNECTIONS WITHOUT PROPER TRAINING. IN EVENT OF AN ACCIDENT FLUSH WITH WATER AND CALL A PHYSICIAN IMMEDIATELY. KEEP OUT OF REACH OF CHILDREN.

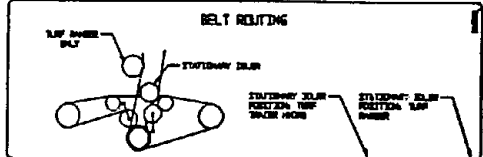

HYDRAULIC OIL RESERVOIR

USE ONLY MOBIL 1 SAE 15W-30 OR 5W-30 SYNTHETIC ENGINE OIL

FILL TO TOP OF BAFFLE

**CAUTION**

1. READ OPERATOR'S MANUAL BEFORE OPERATING.
2. CLEAR AREA OF PEOPLE, PETS AND DEERS BEFORE MOWING.
3. KEEP MOWER OFF.
4. BEFORE STARTING ENGINE:
  - A. BLADE CLUTCH MUST BE DISENGAGED.
  - B. TRANSMISSION MUST BE IN NEUTRAL.
  - C. ON ELECTRIC START ENGINE, OPERATOR MUST BE IN OPERATING POSITION WITH OPERATOR PRESENCE CONTROL LEVER DEPRESSURED.
  - D. ON MANUAL START ENGINE, PLACE LEFT AND RIGHT DRIVE LEVER INTO NEUTRAL LOCK POSITION USING TRAILER LATCHES.
5. BEFORE LEAVING OPERATOR POSITION:
  - A. SHIFT TRANSMISSION TO NEUTRAL.
  - B. DISCHARGE BLADE CLUTCH.
  - C. CLUTCH OFF ENGINE AND REMOVE KEY ON SPARK PLUG CABLE.
6. KEEP ALL SHIELDS AND GUARDS IN PLACE.
7. DO NOT OPERATE MOWER DECK UNLESS ENTIRE GRASS CATCHER OR DISCHARGE DEFLECTOR IS IN PLACE.
8. USE CAUTION ON SLOPES.
9. DO NOT MOW ON SLOPES UNLESS WHEELS ARE CHOCKED OR BLOCKED.
10. SHUT OFF ENGINE AND REMOVE KEY BEFORE SPARK PLUG CABLE IS BEFORE ANY ADJUSTMENTS, SERVICING OR CLEANING.

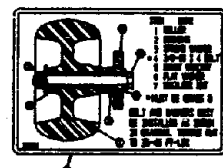

MAY BE MADE UNDER ONE OR MORE OF THE FOLLOWING U.S. PATENTS:

4,978,681 4,913,667 4,920,733

4,941,884 4,958,494

OTHER PATENTS MAY BE PENDING

EXMARK INC. 403080

COMMERCIAL 52

COMMERCIAL 60

TRIVANTAGE

TRACKING LOCK



**WARNING**

Use Only Exmark Riding Attachments. Use of Other Riding Attachments May Create a Hazardous Condition Resulting in Injury.

**DANGER**

KEEP HANDS and FEET AWAY

ON OFF

MOWER

DRIVE WHEEL RELEASE

DO NOT OVER-TIGHTEN

Ref. No.	Part No.	Description	Qty. Req'd.	Ref. No.	Part No.	Description	Qty. Req'd.
1	323525	Decal, Danger	1	14	303520	Decal, Tri-Vantage	1
2	513739	Decal, Ignition	1	15	303293	Decal, 2 Minute Cool	1
3	543631	Decal, Throttle	1	16	613050	Decal, Commercial 60	1
4	613100	Decal, Belt Route	1	17	513890	Decal, Hydraulic Tank	1
5	543626	Decal, Mower Switch	1	18	613044	Decal, "Swash" (large) TTH	1
6	303102	Decal, Neutral Lock	2	19	603845	Decal, Drive Wheel Release	1
7	613169	Decal, Shifter	1	20	613049	Decal, "Swash" (small) TTH	1
8	403132	Decal, Commercial 52	1	21	543660	Decal, Mower Deck	1
9	323540	Decal, Roller Mounting	1	22	303508	Decal, Discharge Warning	1
10	603350	Decal, Instructional	1	23	403005	Danger Label	2
11	513746	Decal, Muffler	1	24	403143	Decal, Sulky Warning	1
12	513747	Decal, Battery	1	25	403080	Decal, Patent No.	1
13	303517	Decal, Belt Drive	1	26	413214	Decal, Tracking	1

# FUEL GROUP

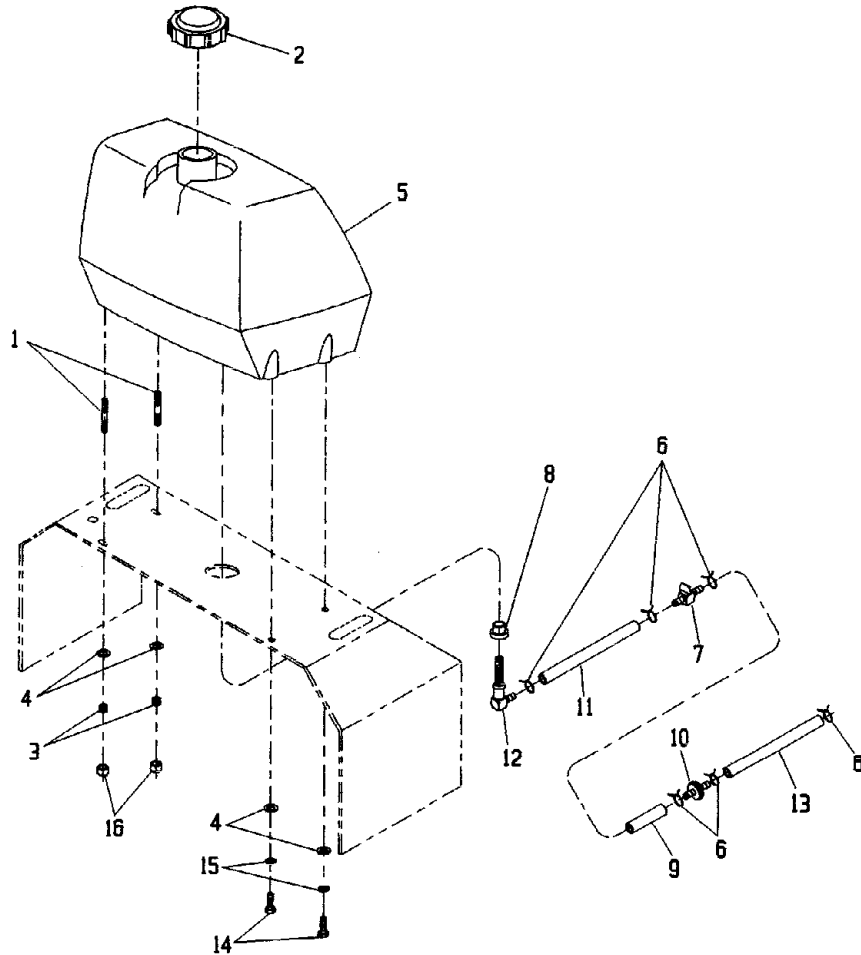

Ref. No.	Part No.	Description	Qty. Req'd.	Ref. No.	Part No.	Description	Qty. Req'd.
1•	633023	Stud, fuel tank .....	2	9	603776	Hose, fuel 2.5.....	1
2	513508	Cap, gas.....	1	10	303197	Filter, fuel.....	1
3	633349	Spring, fuel tank.....	2	11	543649	Hose, fuel 7.0.....	1
4	805256	Washer, flat 1/4 std .....	4	12	543277	Elbow, fuel tank .....	1
5	413179	Gas tank.....	1	13	303306	Hose, fuel 10.5.....	1
6	303077	Clamp, fuel line .....	6	14	800271	Screw, 5/16-18 x 3/4.....	2
7	603770	Valve, fuel .....	1	15	805005	Washer, 5/16 lock.....	2
8	513645	Bushing, fuel .....	1	16	804256	Nut, nylock 5/16-18.....	2

• Use Prolock, Retaining type (P/N 840023) .5cc tube on studs going into tank

# HYDRAULICS GROUP

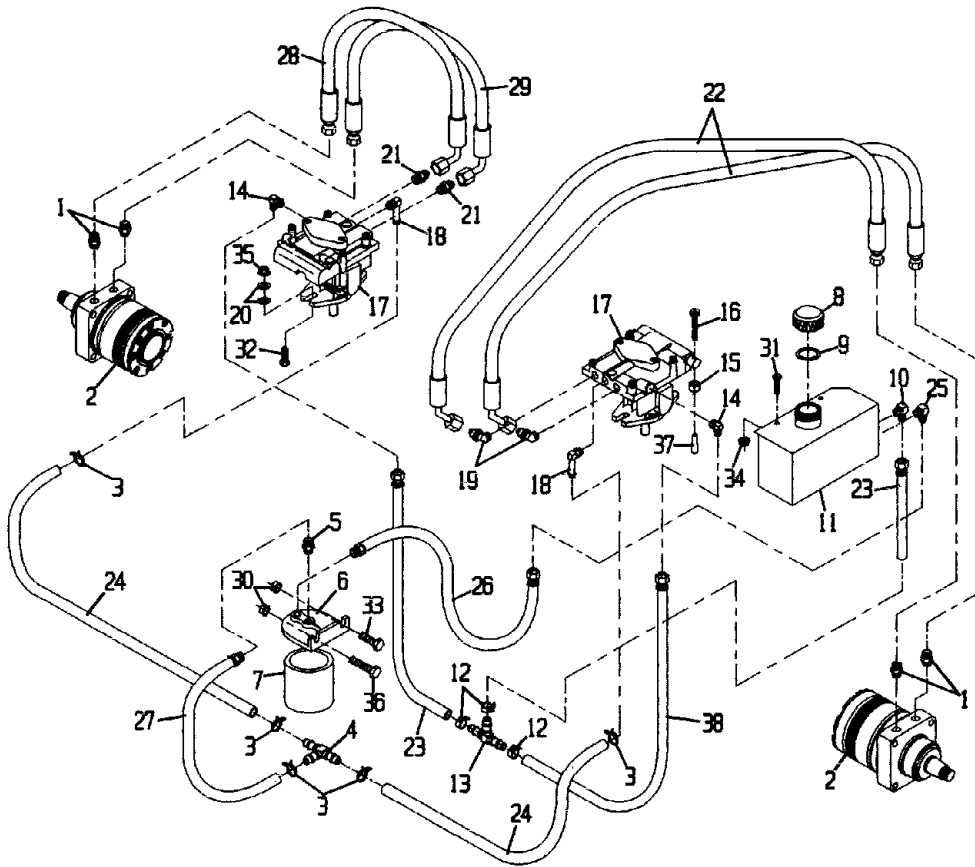

Ref. No.	Part No.	Description	Qty. Req'd.	Ref. No.	Part No.	Description	Qty. Req'd.
1	603991	Fitting, straight connector .....	4	18	603989	Elbow, 90° .....	2
	603919	Boss O-Ring .....	1		603923	O-Ring .....	1
	603992	Flare O-Ring .....	1	19	523221	Elbow, 45° .....	2
2	603718	Motor, wheel .....	2		603992	Flare O-Ring .....	1
	000119	Kit, seal .....	1		603920	Boss O-Ring .....	1
	000138	Kit, bearing .....	1	20	805258	Washer, 5/16 std .....	8
3	603827	Clamp, hose 5/8" .....	5	21	603990	Adapter, straight thread .....	2
4	603721	Fitting, hose tee (3/8 hose) .....	1		603920	Boss O-Ring .....	1
5	513510	Connector, male .....	1		603992	Flare O-Ring .....	1
6*	603720	Head, filter .....	1	22	603981	Hose, hydro (RH) .....	2
7	513211	Element, oil filter .....	1	23	602750	Hose assy, case drain .....	2
Δ	523541	Element, oil filter(winter) .....	1	24	603986	Hose assy, charge pump .....	2
8	513167	Cap, hydraulic reservoir .....	1	25	603988	Elbow, 90° .....	1
9	523103	Gasket, hydr. tank cap .....	1	26	602985	Hose assy, supply .....	1
10	603987	Elbow, 90° .....	1	27	602754	Hose assy, charge line .....	1
11*	512166	Reservoir, hydraulic fluid .....	1	28	613034	Hose, hydro (LH) .....	1
12	603826	Clamp, hose 1/2" .....	3	29	323241	Hose, hydro (LH) .....	1
13	603722	Fitting, hose tee(1/4 I.D hose) .....	1	30	809001	Nut, whizlock 5/16-18 .....	2
14	513840	Elbow, 90° .....	2	31	800252	Screw, 1/4-20 x 3/4 .....	2
	603921	O-Ring .....	1	32	800293	Screw, 3/8-16 x 1-1/4 .....	4
15	804255	Nut, nylock 1/4-20 .....	2	33	800271	Screw, 5/16-18 x 3/4 .....	1
16	801063	Screw, 1/4-20 x 2 pan hd .....	2	34	809012	Nut, whizlock 1/4-20 .....	2
17	613042	Pump, hydro .....	2	35	809007	Nut, whizlock 3/8-16 .....	4
	2513018	Kit, overhaul seal .....	1	36	800273	Screw, 5/16-18 x 1 .....	1
				37	613073	Grip, Dump Valve .....	2
				38	632285	Hose assy .....	1

\* Use Teflon Pipe Sealant or equivalent on hydraulic reservoir fittings and filter head fittings.

Δ Use only for operation below 32° F(0° C)

Exmark black touch up spray paint - Gloss black

# ELECTRICAL GROUP

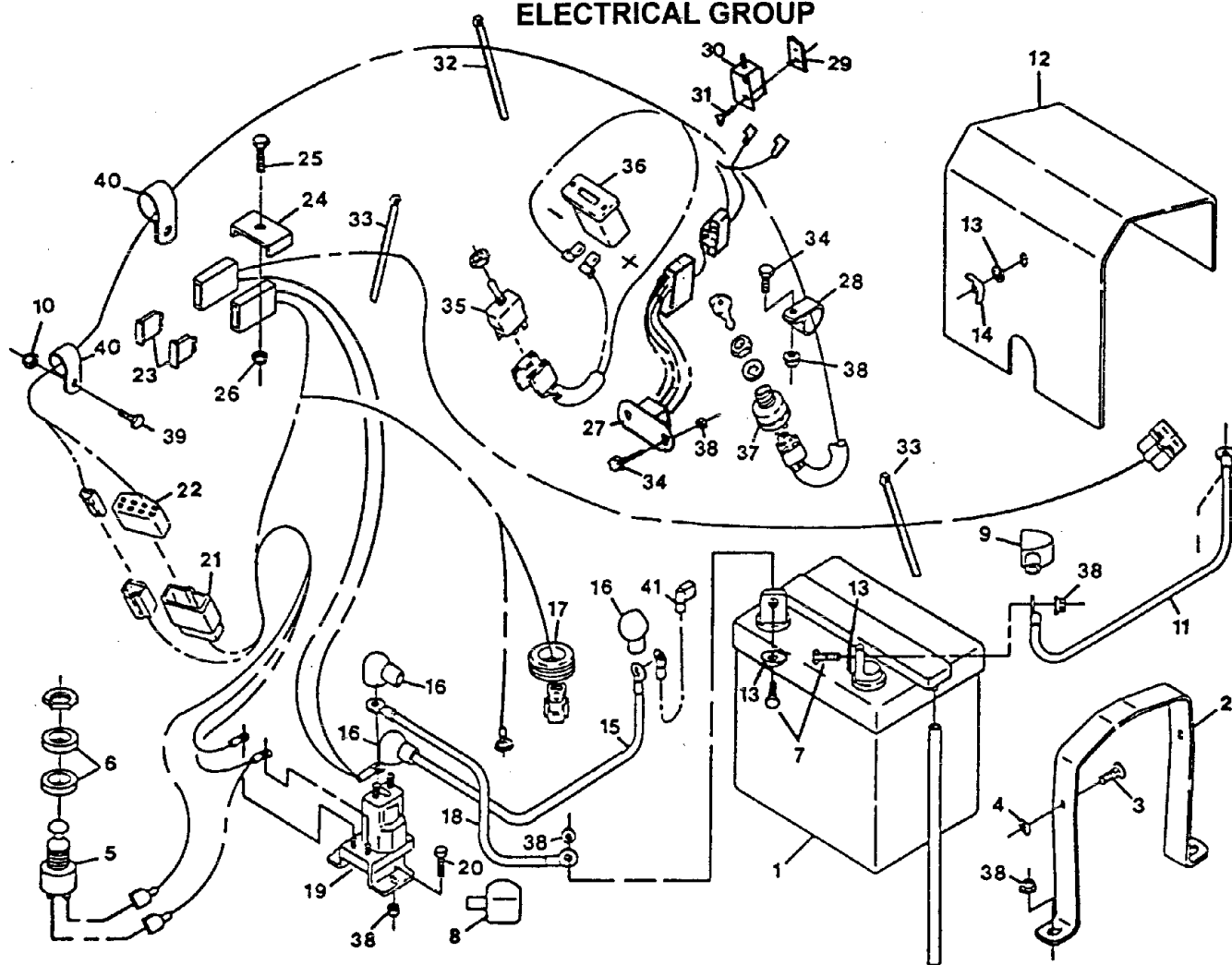

Ref. No.	Part No.	Description	Qty. Req'd.	Ref. No.	Part No.	Description	Qty. Req'd.
1	603479	Battery, 12V manifold .....	1	22	613197	Harness, wire console.....	1
2	603814	Strap, battery holddown .....	1	23	816001	Fuse, blade 20 amp .....	2
3	807512	Bolt, carriage 1/4-20 x 3/4 .....	2	24	603434	Clip, fuse block.....	1
4	803037	Nut, retaining 1/4-20.....	2	25	800256	Screw, 1/4-20 x 1-1/2.....	1
5	603760	Switch, push button .....	1	26	804255	Nut, nylock 1/4-20 .....	1
6	303164	Spacer .....	2	27	613198	Module, Safety Interlock .....	1
7	800252	Screw, 1/4-20 x 3/4 .....	2	28	513762	Clip, 1/2" Loom.....	1
8	543391	Insulator, Battery + .....	1	29	633181	Plate, tapped.....	1
9	543390	Insulator, Battery - .....	1	30	513051	Switch.....	1
10	809007	Nut, whizlock 3/8-16.....	1	31	803028	Screw, #10-24x5/8 .....	2
11	543767	Wire, ground.....	1	32	303335	Plastic tie, (large) .....	1
12	603105	Cover, battery debris.....	1	33	303287	Plastic tie.....	2
13	805256	Washer, 1/4 Flat.....	3	34	800251	Screw, 1/4-20 x 5/8 .....	3
14	803038	Wingnut, 1/4-20 .....	2	35	543018	Switch, toggle.....	1
15	603488	Wire, battery to starter (+) .....	1	36	513374	Meter, engine hour .....	1
16	543393	Insulator, solenoid .....	3	37	543070	Switch, ignition .....	1
17	543286	Grommet .....	1		603511	Keys, ignition.....	1
18	513053	Wire, battery to solenoid (+) ...	1	38	809012	Nut, whizlock 1/4-20.....	9
19	513075	Switch, 12V solenoid .....	1	39	800292	Screw, 3/8-16 x 1 .....	1
20	800250	Screw, 1/4-20 x 1/2 .....	2	40	603727	Clip, 9/16" loom.....	2
21	613010	Harness, engine deck.....	1	41	543084	Wire, starter solenoid .....	1

Exmark black touch up spray paint - Gloss black  
 Apply dielectric grease to all electrical connectors

# ELECTRICAL DIAGRAMS

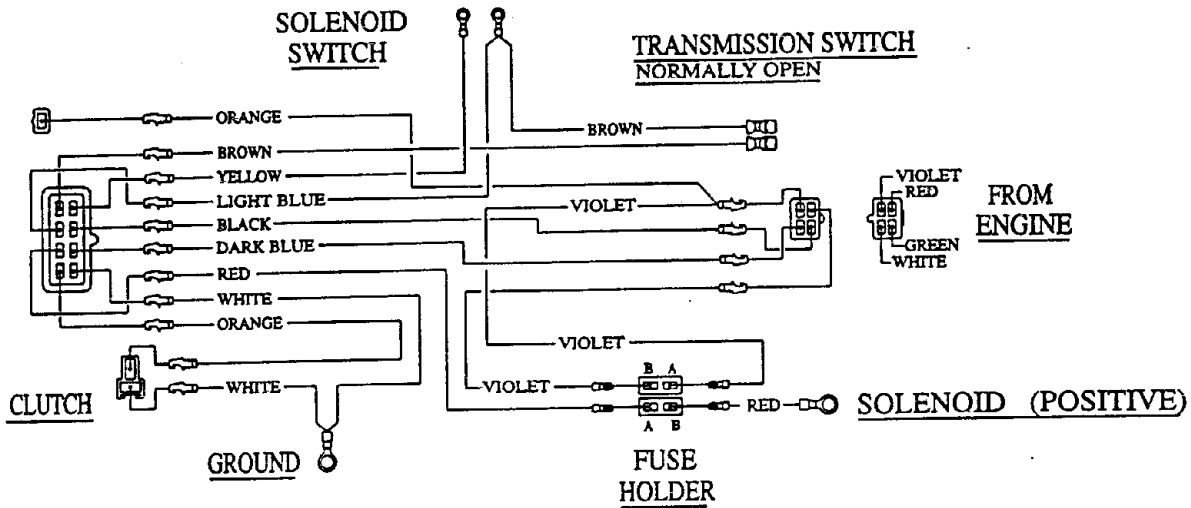

**Engine Deck Wiring Diagram**

NOTE: All connectors are viewed from the *wire input* side of the connector.

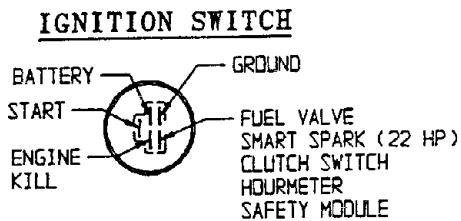
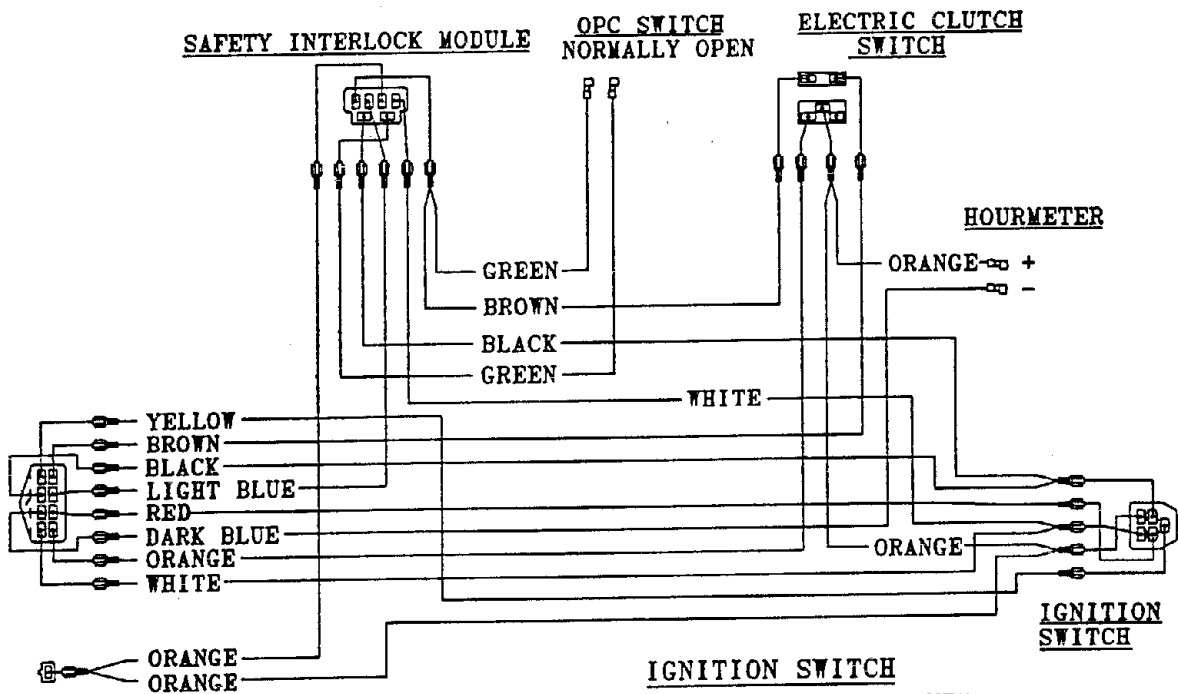

POSITION	CIRCUIT "MAKE"
OFF	GROUND + ENGINE KILL
ON	BATTERY + FUEL VALVE SMART SPARK (22HP) CLUTCH SWITCH HOURMETER SAFETY MODULE
START	BATTERY + START + FUEL VALVE SMART SPARK (22 HP) CLUTCH SWITCH HOURMETER SAFETY MODULE

**Console Wiring Diagram**

NOTE: All connectors are viewed from the *wire input* side of the connector.

**SEE EXMARK'S COMPLETE  
LINE OF PRODUCTS FOR TURF CARE**

**LAZER Z**

**EXPLORER**

**TURF RANGER**

**TURF TRACER HYDRO**

**TURF TRACER HP**

**VIKING 5-SPEED**

**VIKING HYDRO**

**METRO**

**SELF STEERING SULKY**

**GRASS CATCHER**

**MICRO-MULCHING ACCESSORY**

**EXMARK MFG. CO. INC.  
INDUSTRIAL PARK BOX 808  
BEATRICE, NE. 68310**

**ALL RIGHTS RESERVED**

**PART NO. 850438  
(402) 223-4010  
FAX (402) 223-4154**

**PRINTED IN U.S.A.**

