

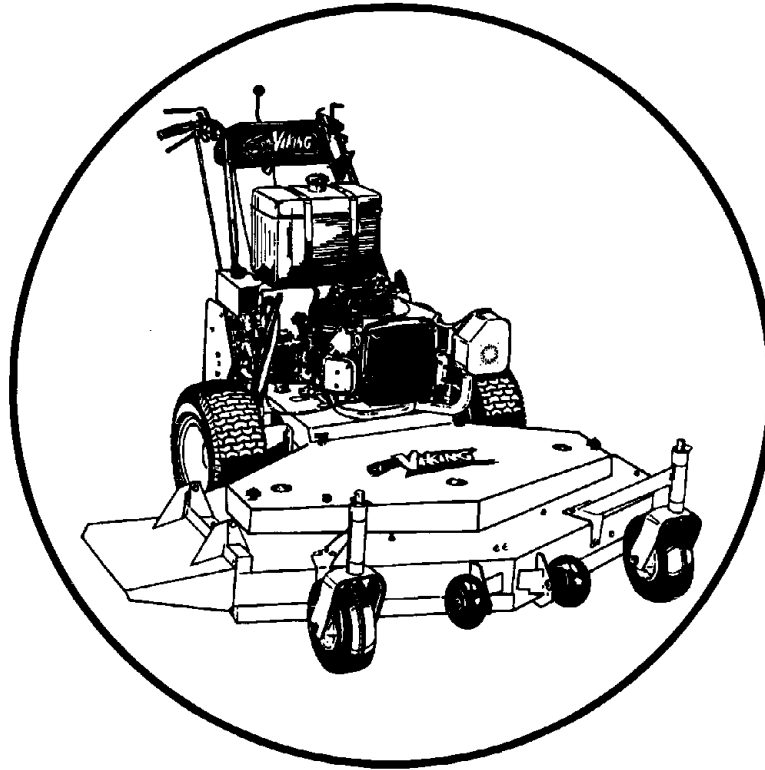

For Serial Nos.
130,000 and Higher

VIKING HYDRO



Parts Manual

CONGRATULATIONS on the purchase of your new Exmark mower. This product has been carefully designed and manufactured to give you a maximum amount of dependability and years of trouble-free operation.

If additional information is needed, or should you require trained mechanic service, contact your authorized Exmark equipment dealer or distributor.

If you need to order replacement parts from your dealer, always give the model number and serial number of your mower as well as the part number, description and quantity of the part needed.

The Serial No. plate is located on the top front engine frame on the right hand side of the machine.

For ease of ordering and reference, we suggest that you record the information requested in the following identification table.

Model No. _____

Serial No. _____

Date Purchased _____

Purchased From _____

Paste Label From
Literature Packet Here

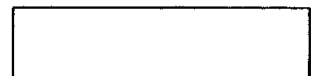

EXMARK PARTS PLUS® PROGRAM

EFFECTIVE DATE: September 1, 1995

Program

If your Exmark dealer does not have the Exmark part in stock, Exmark will get the parts to the dealer the next business day or the part will be FREE* Guaranteed!!

How the Program Works

1. If dealer does not have part in stock for a "down" unit at the time of request by customer, the dealer contacts his distributor by 1:00 p.m., local time, and requests Exmark Parts Plus® shipment of six (6) line items or less.
2. Distributor ships part(s) to dealer or customer, as requested by dealer, same day, overnight UPS Distributor bills dealer for part and freight charges where applicable.
3. If distributor does not have the part(s) in stock to satisfy Exmark Parts Plus® order, he contacts Exmark by 3:00 p.m., central time, with an Exmark Parts Plus® order of six (6) line items or less.
4. If order is received by 3:00 p.m. central time, Exmark ships part(s) direct to dealer or customer, as requested by distributor, same day, overnight UPS Exmark bills the distributor for parts and shipping charges, where applicable.
5. The customer pays for the part and freight if it is shipped under the Exmark Parts Plus® and if it arrive in accordance to the program.
6. Who pays for the part and freight if it fails to arrive overnight in accordance to the program?
 - A. Under any circumstance the customer does not pay.
 - B. If the part does not arrive overnight due to:
 1. The dealer not submitting the Exmark Parts Plus® order to his Exmark distributor by 1:00 p.m., the dealer pays for the part and freight.
 2. The Distributor being unable to ship the part the same day or not submitting the Exmark Parts Plus® order to Exmark by 3:00 p.m., central time, the Distributor pays for the part and freight.
 3. Exmark being unable to ship the part and the Exmark parts order is received by 3:00 p.m., central time, Exmark pays for the part and freight.
 4. If the part does not arrive overnight due to the shipper (UPS), the shipper pays for the freight and Exmark pays for the part.



The following restrictions apply -- The Exmark Parts Plus® Program is available only through participating Exmark Dealers and applies only to orders submitted on this program Monday through Thursday. UPS has initiated a Saturday delivery program to many areas of the continental United States and can be requested for an overnight shipment on Friday to be delivered Saturday. The next day air charge, plus the Saturday delivery fee will be the responsibility of the purchaser. Exmark Mfg. will assume no responsibility for Saturday delivery shipments. To qualify, all Exmark Parts Plus® orders must be received by Exmark by 3:00 p.m., central time. Orders must be six (6) line items or less. Exclusions from the Exmark Parts Plus® Program are: Any wholegood or accessory in its entirety, engines and engine replacement parts, 5-speed Peerless transmissions and 5-speed transaxles, hydraulic or hydrostatic wheel motors, cutter decks and engine decks or any item exceeding United Parcel Service size and weight restrictions.

Due to UPS restrictions, aerosol spray paint is considered a hazardous material and cannot be shipped via UPS next day or Second Day Air.

Exmark Manufacturing stocks a limited supply of parts for transaxles, pumps and wheel motors. These parts can be ordered for Next Day Air shipment but will not be guaranteed per the Parts Plus Program.



**READ OPERATOR'S MANUAL BEFORE
OPERATING OR SERVICING EXMARK EQUIPMENT.**

TABLE OF CONTENTS

<u>Description</u>	<u>Page</u>
Decals	13
Engine Deck Group	10-12
52" Mower Deck	7-9
48" Mower Deck	4-6
Hydraulics Group	16
36" Mower Deck	2-3
Upper Handles & Controls	14-15
Wiring Diagrams	17

36" MOWER DECK

Ref. No.	Part No.	Description	Qty. Req'd.	Ref. No.	Qty. Part No.	Description	Req'd.
1	302227	Front Deck w/decals & dogleg	1	34	323417	Washer, belt cover mount	4
	302224	Deck weldmt (36")	1	35	322145	Fork wldmnt, caster	2
2	302189	Baffle wldmnt, dogleg	1	36	322154	Caster wheel assembly	2
3	800270	5/16-18 x 5/8 HHCS	8	37	302054	Chute	1
4	809001	5/16-18 Whizlock nut	13	38	302129	Engagement arm w/bushing	1
5	302128	Arm weldmt	1	39	303144	Powder metal bearing	1
6	303542	O-Ring	2	40	800290	3/8-16 x 3/4 HH capscrew	8
7	811006	Zerk, 1/4-28 STRT	1	41	603843	Idler pulley (heavy duty)	1
8	323385	Knob, belt cover	4	42	322166	Cutter housing w/sheave	2
9	809020	Quick pin, 10" caster	2	43	323402	Spacer, bearing sheave	2
10	804256	5/16-18 Nylock hex nut	11	44	323408	Dust shield	2
11	800292	3/8-16 x 1 HH capscrew	6	45	808506	Retaining ring	2
12	809007	3/8-16 whizlock nut	8	46	303543	Cutter housing bearing	4
13	805259	3/8 Flatwasher	1	47	323315	Cutter housing	2
14	303327	3/8 Disc spring washer	6	48	811001	1/8 N.P.T. Straight zerk	2
15	808280	5/16 x 1 Clevis pin	1	49	322164	Cutter spindle wldmnt	2
16	303105	Yoke	1	50	323400	Spacer (long)	2
17	806003	Cotter hairpin	1	51	323399	Spacer (short)	2
18	808505	E-Ring for .875 rd.	1	52	323339	Washer, retaining	2
19	803003	3/8-16 x 1 3/4 Whizlock bolt	1	53	303535	Pulley, cast iron	2
20	633482	Blade, 18" High Lift (Std.)	2	54	804510	5/8-18 UNF hex nut	2
	633484	Blade, Mulching (36")	2	55	800861	5/8-18 x 8 HH Capscrew (Gr 5)	2
	633485	Blade, Low Lift (36") optional	2	56	807267	Key, 1/4 x 3/16 x 1 1/4	2
21	513338	Washer, special	2	57	303164	Spacer, blade drive	8
22	805008	1/2 spring lockwasher	2	58	513208	5/8 Spring disc washer	2
23	804509	1/2-13 Hex nut	2	59	303434	Engagement bushing	1
24	800334	1/2-13 x 6 HH capscrew	2	60	303348	Eye bolt (left hand thread)	1
25	303352	Washer, spindle	1	61	303236	Turnbuckle body	1
26	513648	Wheel & tire, complete	2	62	303238	Eye bolt (right hand thread)	1
	513807	Wheel & hub	1	63	302198	Assist arm	1
	513808	Tire, 9 x 3.50-4 4-ply	1	64	809011	3/8 x 3/4 Shoulder bolt	1
	513809	Roller bearing	1	65	323174	Assist arm linkage	1
	513810	Bushing	2	66	322153	Caster/mount, complete	1
27	323200	Drive belt 36" Model	1	67	302203	Caster wheel support w/bearings	2
◆28	803310	Setscrew, 5/16-18 x 3/8	2	68	302194	Caster wheel support wldmnt	2
29	800273	5/16-18 x 1 HH capscrew	10	69	811001	Grease zerk, 1/8 N.P.T.	2
30	513547	Spacer, front caster	2	70	303514	Flange, thrust bearing	4
31	303537	Stud, belt shield (short)	2	71	303314	Spacer, 10" caster	8
32	303536	Stud, belt shield (long)	2	72	806753	Pin, cotter 3/32 x 1/2	1
33	302218	Shield w/decals, 36" Vik hydro	1				
	302213	Shield weldmt, 36" Vik hydro	1				

◆ Use Pro-lock Nut Type (p/n 840022 .5 ml tube) on setscrews

• Requires installation of Micro-Mulch accessory for proper mulching. Mulch kit P/N MK362(36")

Exmark red touch up spray paint - P/N 850337

48" MOWER DECK

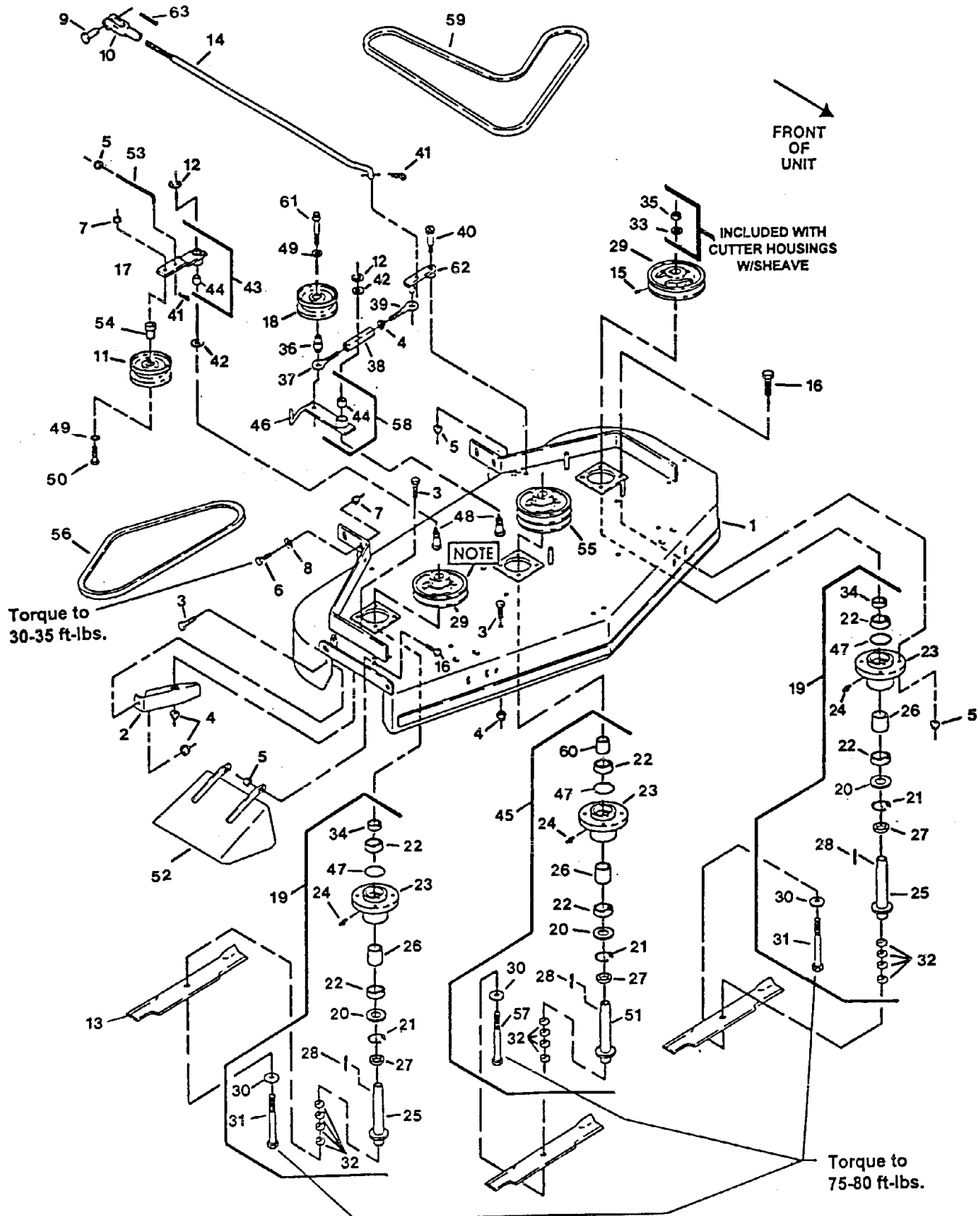

48" MOWER DECK

Ref. No.	Part No.	Description	Qty. Req'd.	Ref. No.	Part No.	Description	Qty. Req'd.
1*	402096	Front Deck w/decals & dogleg	1	32	303164	Spacer, blade drive.....	12
*	402091	Deck Weldmt, (48")	1	33	323339	Washer,retainer (sheave)	3
2	302189	Baffle, dogleg	1	34	323402	Spacer, bearing (sheave)	2
3	800270	5/16-18 x 5/8 HH capscrew.....	10	35	804510	5/8-18 UNF hex nut	3
4	809001	5/16-18 Whizlock nut.....	11	36	303434	Engagement bushing	1
5	804256	5/16-18 Nylock hex nut	16	37	303348	Eye bolt (left hand thread).....	1
6	800292	3/8-16 x 1 HH capscrew.....	6	38	303236	Turnbuckle body.....	1
7	809007	3/8-16 whizlock nut	7	39	303238	Eye bolt (right hand thread).....	1
8	303327	3/8 disc spring washer	6	40	809011	3/8 x 3/4 Shoulder bolt.....	1
9	808280	5/16 x 1 Clevis pin.....	1	41	806003	Cotter hairpin.....	2
10	303105	Yoke	1	42	303352	Washer, spindle.....	2
11	403119	Idler pulley "V".....	1	43	402053	Idler arm, complete(w/bushing).....	1
12	808505	E-Ring for .875 rd.....	2	44	303144	Powder metal bearing	2
13	323515	Blade, Ultra High Lift 16" (48").....	3	45	402077	Cutter housing w/sheave(center).....	1
•	403148	Blade, mulching (48")	3	46	302128	Arm weldmt.....	1
	403149	Blade, Low Lift (48") optional	3	47	303542	O-Ring	3
14	323174	Assist arm linkage	1	48	811006	Zerk 1/4-28 STRT	2
◆15	803310	Setscrew, 5/16-18 x 3/8	3	49	805259	3/8 Flatwasher	3
16	800273	5/16-18 x 1 HH capscrew.....	14	50	800295	3/8-16 X 1 3/4 HH capscrew.....	1
17	402052	Arm weldmt, RH	1	51	402075	Cutter spindle wldmnt, center (long) .	1
18	603843	Idler pulley	2	52	302054	Chute	1
19	322166	Cutter Housing w/sheave (LH).....	2	53	403107	Belt tension rod	1
20	323408	Dust shield	3	54	603496	Bushing, idler bearing	1
21	808506	Retaining ring	3	55	403133	Double pulley	1
22	303543	Cutter housing bearing	6	56	403025	V-Belt, front deck	1
23	323315	Cutter housing	3	57	800862	5/8-18 x 8 1/2 HH capscrew, Gr5	1
24	811001	1/8 N.P.T. Straight zerk	3	58	302129	Engagement arm w/bushing	1
25	322164	Cutter spindle wldmnt (LH).....	2	59	303499	Drive belt 48"	1
26	323400	Spacer (long).....	3	60	323404	Spacer, bearing (center sheave)	1
27	323399	Spacer (short)	3	61	803003	3/8-16 x 1 3/4 Whizlock bolt.....	1
28	807267	Key, 1/4 x 3/16 x 1 1/4	3	62	302198	Assist arm	1
29	303535	Pulley, cast iron.....	2	63	806753	Pin, cotter.....	1
30	513208	5/8 Spring disc washer.....	3				
31	800861	5/8 -18 x 8 HH Capscrew	2				

◆ Use Pro-lock Nut Type (p/n 840022 .5 ml tube) on setscrews

• Requires installation of Micro-Mulch accessory for proper mulching. Mulch kit P/N MK482

NOTE: Pulley (Part No. 303535) on the *right hand* side (from operators position) is turned upside down with the long side of the hub facing up

Exmark red touch up spray paint - P/N 850337

* Deck weldmt does not include flow control baffles - Flow control baffle kit is available P/N 401002

48" MOWER DECK (con't)

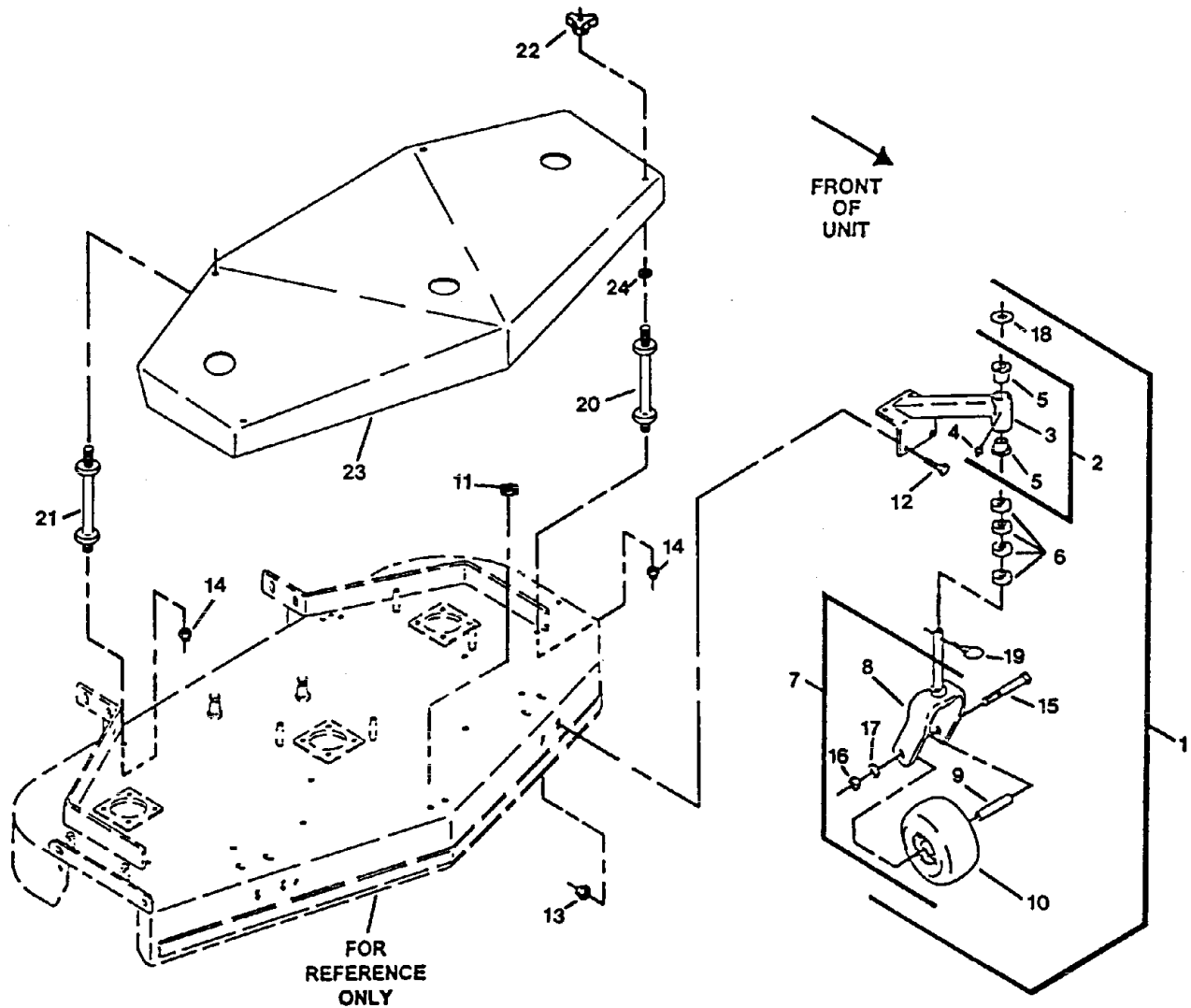

Ref. No.	Part No.	Description	Qty. Req'd.	Ref. No.	Part No.	Description	Qty. Req'd.
1	322153	Caster mount complete	2	11	403145	Rubber Bumper	1
2	302203	Support, caster wheel (w/bearings)	2	12	800290	Screw, 3/8-16 x 3/4	8
3	302194	Support, caster wheel wldmnt.	2	13	809007	Nut, 3/8-16 whizlock	8
4	811001	Zerk, 1/8 N.P.T.	2	14	809001	Nut, 5/16-18 whizlock	4
5	303514	Flange, thrust bearing	4	15	800334	Screw, 1/2-13 x 6	2
6	303314	Spacer, 10" caster	8	16	804509	Nut, 1/2-13 hex	2
7	322154	Wheel assembly (caster)	2	17	805008	Washer, 1/2 spring lock	2
8	322145	Fork wldmnt, caster	2	18	513338	Washer, special	2
9	513547	Spacer, front caster	2	19	809020	Quick pin, 10" caster	2
10	513648	Wheel & tire, complete	2	20	303537	Stud, belt shield(short)	2
	513807	Wheel & hub	2	21	303536	Stud, belt shield(long)	2
	513808	Tire, 9 x 3.50-4 4-ply	2	22	323385	Knob, belt cover	4
	513809	Roller bearing	2	23	402072	Shield w/decals 48" vik hydro.	1
	513810	Bushing	4		402064	Shield weldmt 48" vik hydro ...	1
				24	323417	Washer, belt cover mount	4

Exmark red touch up spray paint - P/N 850337

52" MOWER DECK

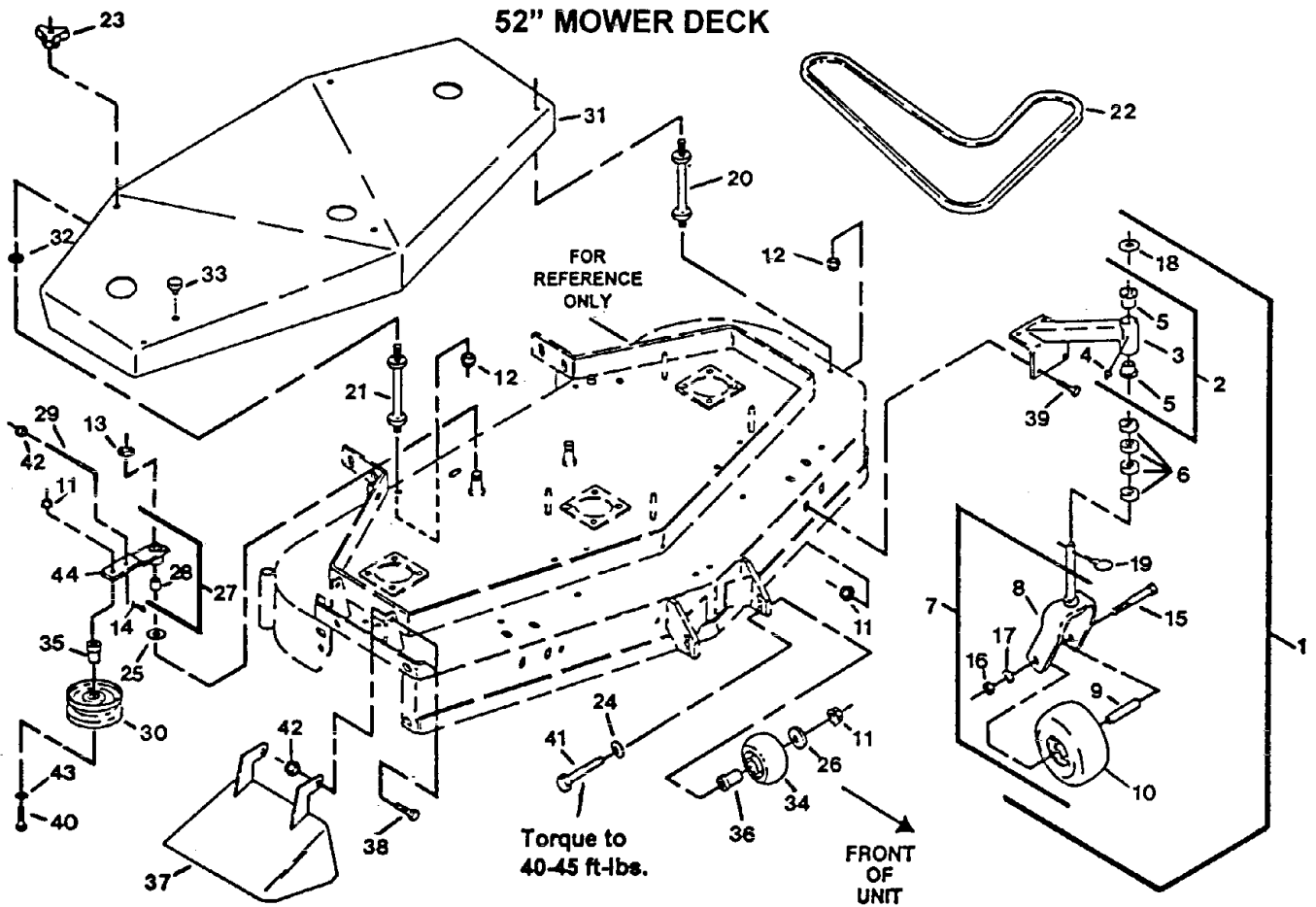

Ref. No.	Part No.	Description	Qty. Req'd.	Ref. No.	Part No.	Description	Qty. Req'd.
1	322153	Caster mount, complete.....	2	21	303536	Stud, belt shield(long)	3
2	302203	Support, caster wheel (w/bearings).....	2	22	403088	Drive belt.....	1
3	302194	Support, caster wheel wldmnt.	2	23	323385	Knob, belt cover.....	5
4	811001	Zerk, 1/8 N.P.T.	2	24	303327	Washer, 3/8 disc spring.....	2
5	303514	Flange, thrust bearing.....	4	25	303352	Washer, spindle	1
6	303314	Spacer, 10" caster	8	26	373034	Washer, pivot	2
7	322154	Wheel assembly (caster).....	2	27	402053	Idler arm, complete(right).....	1
8	322145	Fork wldmnt, caster	2	28	303144	Bushing, powdered metal.....	1
9	513547	Spacer, front caster	2	29	403107	Belt tension rod.....	1
10	513648	Wheel & tire, complete.....	2	30	403119	Pulley, idler "v"	1
	513807	Wheel & hub	2	31	402071	Shield w/decals	1
	513808	Tire, 9 x 3.50-4 4-ply.....	2		402069	Shield weldmt.....	1
	513809	Roller bearing	2	32	323417	Washer, belt cover mount.....	5
	513810	Bushing	4	33	513291	Bumper, rubber	1
11	809007	Nut, 3/8-16 whizlock	11	34	603299	Roller, anti scalp.....	2
12	809001	Nut, 5/16-18 whizlock	4	35	603496	Bushing, idler bearing	1
13	808505	E-ring for .875 rod.....	1	36	603602	Bushing, roller.....	2
14	806003	Cotter hairpin	1	37	602571	Chute.....	1
15	800334	Screw, 1/2-13 x 6.....	2	38	800273	Screw, 5/16-18 x 1	2
16	804509	Nut, 1/2-13 hex	2	39	800290	Screw, 3/8-16 x 3/4	8
17	805008	Washer, 1/2spring lock	2	40	800295	Screw, 3/8-16 x 1-3/4.....	1
18	513338	Washer, special	2	41	800807	Screw, 3/8-16 x 4 Gr8.....	1
19	809020	Quick pin, 10" caster.....	2	42	804256	Nut, 5/16-18 Nylock	3
20	303537	Stud, belt shield	2	43	805259	Washer, 3/8 flat.....	1
				44	402052	Arm weldmt	1

Exmark red touch up spray paint - P/N 850337

52" MOWER DECK (con't)

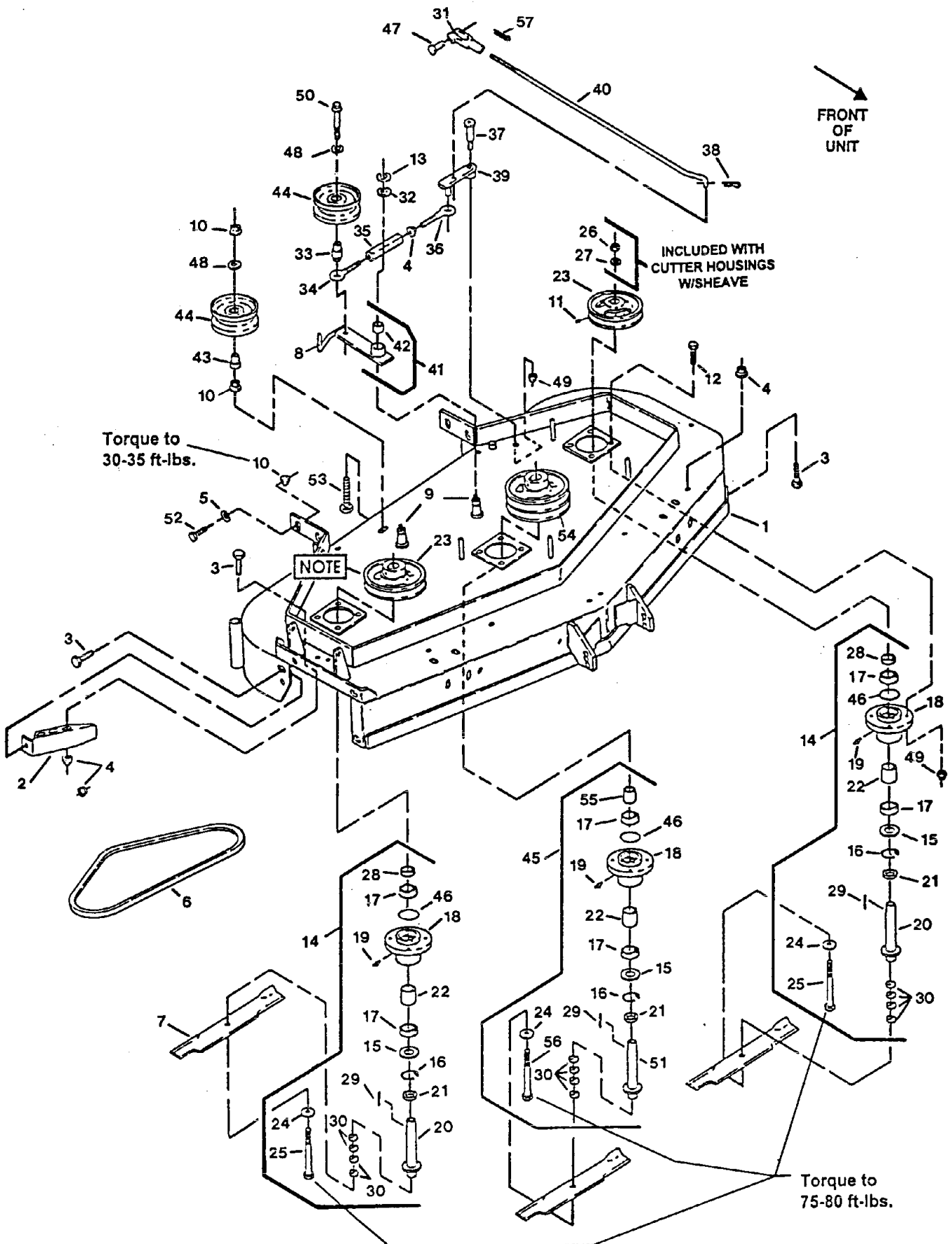

52" MOWER DECK (con't.)

Ref. No.	Part No.	Description	Qty. Req'd.	Ref. No.	Part No.	Description	Qty. Req'd.
**1	402060	Deck weldmt w/decals & dogleg	1	27	323339	Washer, retainer (sheave)	3
**	402079	Deck weldmt.....	1	28	323402	Spacer, bearing	2
*	402101	Deck weldmt w/decals & dogleg	1	29	807267	Key, 1/4 x 3/16 x 1 1/4.....	3
*	402098	Deck weldmt.....	1	30	303164	Spacer, blade drive.....	12
2	402057	Baffle wldmnt, discharge	1	31	303105	Yoke	1
3	800270	5/16-18 x 5/8 HHCS	11	32	303352	Washer, spindle.....	1
4	809001	5/16-18 Whizlock nut.....	11	33	303434	Engagement bushing.....	1
5	303327	3/8 Disc spring washer.....	7	34	303348	Eye bolt (left hand thread)	1
6	403105	V-Belt, front deck.....	1	35	303236	Turnbuckle body.....	1
7	633482	Blade, High Lift 18" (52").....	3	36	303238	Eye bolt (right hand thread).....	1
	633485	Blade, Low Lift.....	3	37	809011	3/8 x 3/4 Shoulder bolt.....	1
•	633484	Blade, mulching.....	3	38	806003	Cotter hairpin.....	1
8	302128	Arm weldmt	1	39	302198	Assist arm..	1
9	811006	Zerk, 1/4-28 STRT	2	40	403111	Assist arm linkage	1
10	809007	3/8-16 Whizlock nut.....	8	41	302129	Engagement arm w/bushing.....	1
◆11	803310	Setscrew, 5/16-18 x 3/8	3	42	303144	Bushing, powdered metal.....	1
12	800273	5/16-18 x 1 HH capscrew.....	12	43	543879	Bushing, idler.....	1
13	808505	E-Ring for .875 rd.	1	44	603843	Idler pulley (heavy duty)	2
14	322166	Cutter housing w/sheave (LH).....	2	45	402077	Cutter housing w/sheave (center)	1
15	323408	Dust shield.....	3	46	303542	O-Ring	3
16	808506	Retaining ring	3	47	808280	5/16 x 1 Clevis pin	1
17	303543	Cutter housing bearing	6	48	805259	3/8 Flatwasher	3
18	323315	Cutter housing	3	49	804256	5/16-18 Nylock hex nut.....	13
19	811001	1/8 N.P.T. Straight zerk.....	3	50	803003	3/8-16 x 1 3/4 Whizlock bolt	1
20	322164	Cutter spindle wldmnt.....	2	51	402075	Cutter spindle wldmnt (long)	1
21	323399	Spacer (short)	3	52	800292	3/8-16 x 1 HH capscrew	6
22	323400	Spacer (long).....	3	53	800029	3/8-16 x 2 1/4 HH tap bolt.....	1
23	303535	Pulley, cast iron.....	2	54	403133	Double pulley.....	1
24	513208	5/8 Spring disc washer.....	3	55	323404	Spacer, bearing (center sheave).....	1
25	800861	5/8-18 x 8 HH Capscrw (Gr 5).....	2	56	800862	5/8-18 x 8 1/2 HH capscrew, Gr5.....	1
26	804510	5/8-18 UNF hex nut.....	3	57	806753	Pin, cotter.....	1

NOTE: Pulley (Part No. 303535) on the *right hand* side (from operators position) is turned upside down with the long part of the hub facing upward.

- ◆ Use Pro-lock Nut Type (p/n 840022 .5 ml tube) on setscrews
- Requires installation of Micro-Mulch accessory for proper mulching. Mulch kit P/N MK52M2 (units without flow control baffles welded in deck) or MK523 (units with flow control baffles welded in deck)

Exmark red touch up spray paint - P/N 850337

* Deck weldmt does include welded in flow control baffles

** Deck weldmt does not include flow control baffles - Flow control baffle kit is available P/N 611104

ENGINE DECK GROUP

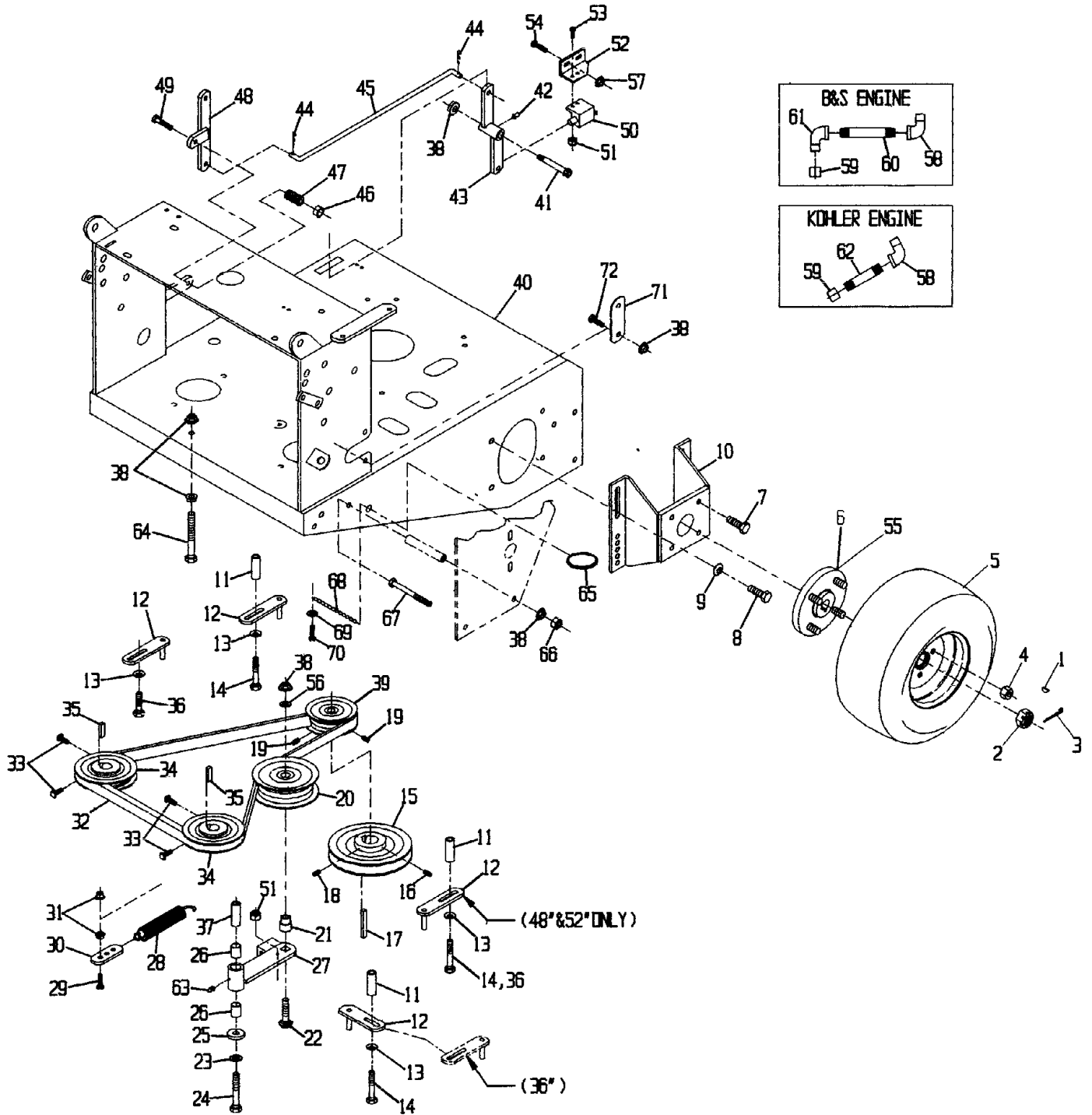

ENGINE DECK GROUP

Ref. No.	Part No.	Description	Qty. Req'd.	Ref. No.	Part No.	Description	Qty. Req'd.
1	807019	Key, woodruff 1 x 1/4.....	2	33▽	803050	Setscrew, 5/16-18 x 3/4.....	4
2	803040	Nut, slotted 3/4-16.....	2	34	603778	Sheave - pump.....	2
3	806800	Pin, cotter 9/64 x 1-1/2.....	2	35	807272	Key, 5mm sq. x 25mm.....	2
4	513011	Nut, wheel 1/2-20.....	8	36	809072	Screw, 1.25 x 25mm	
5	603714	Tire & Wheel Assembly.....	2			(36" Kaw)(48" Koh).....	1
	603427	Tire 16 x 6.50-8.....	1			(36"Kohler).....	2
	603715	Wheel.....	1		800275	Screw, 5/16-18 x 1-1/2 (B & S)	1
6*	602997	Hub, tapered (4 bolt)w/studs...	2		809018	Screw, 1.25 x 30mm	
7	803045	Screw, whizloc 3/8-16 x 3/4....	8			(36"Kaw & 48"Kaw).....	1
8	800292	Screw, 3/8-16 x 1.....	8	37	603044	Bushing - Idler pivot.....	1
9	303327	Washer, 3/8 spring disc.....	8	38	809007	3/8-16 Whizlock Nut.....	10
10	322162	Mount, motor (36").....	2	39◇	403092	Pulley, pump drive.....	1
	402062	Mount, motor (48" & 52").....	2	40	322199	Deck, engine wldmt.....	1
11	323228	Spacer, belt guide(48"&52")....	3	41	809062	Bolt, .500 x 1.75 (shoulder)....	1
	323228	Spacer, belt guide(36").....	2	42	811008	Zerk.....	1
12	322110	Belt guide (36").....	3	43	322108	Bellcrank assy. w/zerk.....	1
	322110	Belt guide (48"&52").....	4		322086	Bellcrank weldmt.....	1
13	303334	Washer, 5/16 spring disc.....	4	44	806003	Hairpin.....	2
14	809065	Screw, 1.25 x 75mm		45	323172	Linkage, blade engagement...	1
		(36" Kaw & Kohler).....	2	46	804256	Nut, nylock 5/16-18.....	1
	809065	Screw, 1.25 x 75mm		47	323245	Spring, compression.....	1
		(48" & 52" Kaw & Kohler).....	3	48	322090	Bellcrank.....	1
	800283	Screw, 5/16-18 x 3-1/2		49	800277	Screw, 5/16-18 x 2.....	1
		(B & S).....	3	50	513051	Switch, blade engagement.....	1
15*	403087	Sheave, blade drive (48").....	1	51	804252	Nut nylock 10-24.....	3
	303498	Sheave, blade drive (36"&52")	1	52	323213	Bracket, switch.....	1
16▽	803046	Setscrew, 5/16-18 x 1.....	1	53	803028	Screw, 10-24 x 5/8.....	2
17	807264	Key, 1/4 sq. x 2-5/8.....	1	54	800251	Screw, 1/4-20 x 5/8.....	2
18▽	803050	Setscrew, 5/16-18 x 3/4.....	1	55	613150	Stud, hub 1/2-20.....	8
19▽	803310	Setscrew, 5/16-18 x 3/8.....	2	56	805259	Washer, 5/16(SAE).....	1
20	603843	Idler, pulley.....	1	57	809012	Nut, whizlock 1/4-20.....	2
21	603496	Bushing, idler.....	1	58◆	303431	Elbow St. 3/8 NPT (brass).....	1
22	807517	Screw, 3/8-16 x 1-3/4.....	1	59◆	543233	Cap, 3/8 NP.....	1
23	805006	Lockwasher, 3/8.....	1	60◆	543232	Nipple, 4 x 3/8 NPT.....	1
24	800298	Screw, 3/8-16 x 2-1/2.....	1	61◆	403124	Elbow, St. 3/8 NPT (galv).....	1
25	373034	Washer, swivel.....	1	62◆	323326	Nipple, 3 3/8 NPT (Kohler).....	1
26	513034	Bearing, pivot.....	2	63	811006	Zerk, 1/4-28 STRT.....	1
27	602521	Arm, assy idler (w/bearings)...	1	64	800297	Screw, 3/8-16 x 4.....	1
	602458	Arm, assy idler (w/o bearings)	1	65	323366	Split ring.....	1
28	603402	Spring, extension.....	1	66	804257	Nut, 3/8-16 nylock.....	1
29	800273	Screw, 5/16-18 x 1.....	1	67	800303	Screw, 3/8-16 x 4 1/2.....	1
30	603801	Anchor, spring.....	1	68	323365	Chain, twist link.....	1
31	809001	Nut, whizlock 5/16-18.....	2	69	805252	Washer, #10.....	1
	809001	Nut, whizlock 5/16-18(B&S)....	6	70	809069	Screw, 10-24 x 7/8HxSktHd...	1
32	323225	Belt, pump drive.....	1	71	633068	Arm.....	1
				72	800290	Screw, 3/8-16 x 3/4.....	2

* Use anti-seize compound on pulley bore and on tapered bore of hub.

▽ Use Pro-Lock (nut type, Part no. 840022, 5 ml tube) on setscrew threads.

◆ Use a Teflon pipe sealant of equivalent on threads.

Exmark red touch up spray paint - P/N 850337

◇ Use Pro-Lock (retaining type, Part no. 840023, .5cc tube) on pulley.

ENGINE DECK GROUP (con't.)

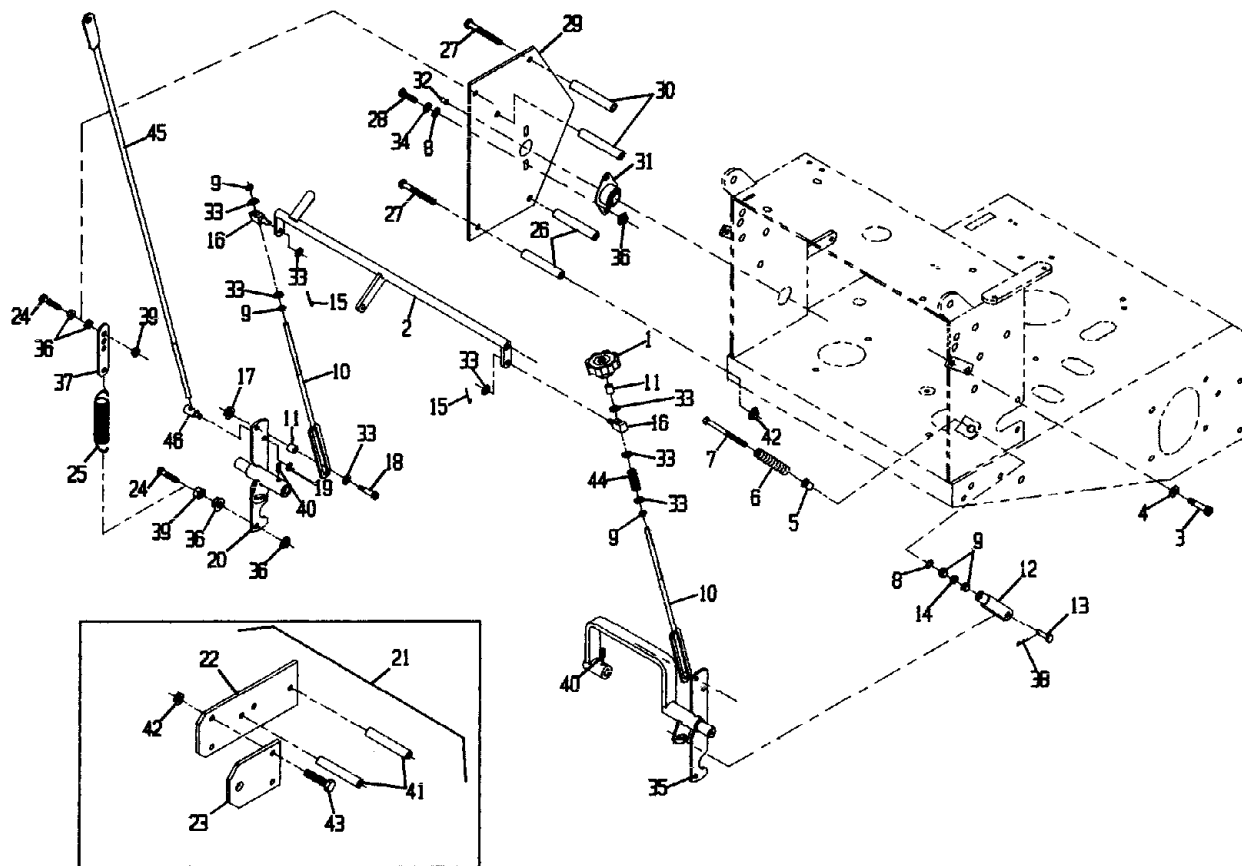

Ref. No.	Part No.	Description	Qty. Req'd.	Ref. No.	Part No.	Description	Qty. Req'd.
1	413151	Knob, tracking.....	1	24	800274	Screw, 5/16-18 x 1-1/4.....	4
2	412203	Crank weldmt.....	1	25	603693	Spring, extension.....	2
3*	809056	Bolt, .375 x .375 (shoulder)	2	26	323197	Spacer, short.....	4
4	805259	Washer, 3/8 (sae).....	2	27	800302	Screw, 3/8-16 x 4.....	7
5	603735	Bushing, nylon flanged.....	2	28	800271	5/16-18 x 3/4.....	4
6	603807	Spring, neutral return.....	2	29	413201	Shield, hydro control.....	2
7	603737	Bolt, neutral return.....	2	30	323195	Spacer, long.....	4
8	805256	Washer, 1/4(std).....	6	31	633102	Bearing, flange.....	2
9	804521	Nut, 5/16-24.....	7	32	811006	Zerk, 1/4-28.....	2
10	412276	Rod, control arm.....	2	33	805257	Washer, 5/16 (SAE).....	9
11	603903	Spacer.....	3	34	805005	Lockwasher, 5/16 (heavy).....	4
12	303105	Yoke, adjustable.....	2	35	412270	Arm weldmt, RH.....	1
13	808280	Pin, clevis 5/16-1.....	2	36	809001	Nut, whizlock 5/16.....	12
14	804758	Nut, jam 5/16-24.....	2	37	613089	Anchor, spring.....	2
15	806753	Pin, cotter 3/32 x 1/2.....	2	38	806003	Hairpin.....	2
16	603676	Swivel.....	2	39	804256	Nut, nylock 5/16-18.....	4
17	809012	Nut, 1/4-20 whizlock.....	2	40*	803022	Setscrew, 5/16-18 x 5/8.....	2
18*	809057	Bolt, .312 x .750 (shoulder)	2	41	323240	Spacer, shield.....	4
19	808520	Klipring.....	2	42	809007	Nut, whizlock 3/8-16.....	12
20	412272	Arm weldmt, left hand.....	1	43	800292	Screw, 3/8-16 x 1.....	4
21	301022	Sulky hitch kit, (Vik Hydro).....	1	44	323245	Spring.....	2
22	373036	Mount, hitch.....	1	45	413219	Linkage, drive.....	2
23	323238	Bracket, hitch adapter.....	2	46	413227	Swivel, drive lever.....	2

* Use Pro-Lock nut type, Part No. 840022 (.5 ml tube) on bolt & setscrew threads.
 Exmark red touch up spray paint - PN 850337

DECALS

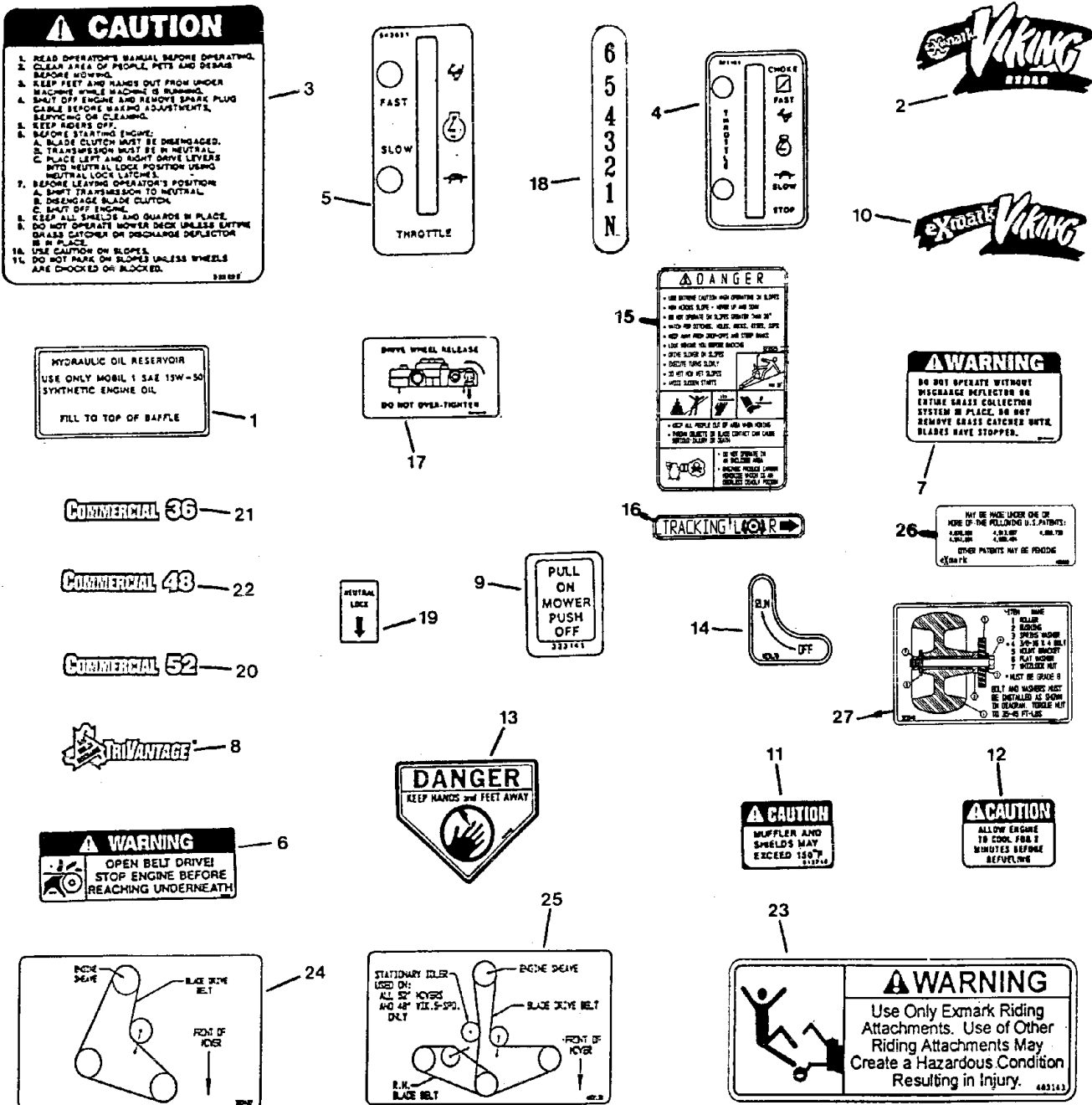

Ref. No.	Part No.	Description	Qty. Req'd.	Ref. No.	Part No.	Description	Qty. Req'd.
1	513890	Decal, Hydraulic Tank	1	14	403120	Decal, Off/Run (B&S)	1
2	323319	Decal, Large Vik Hydro	1	15	323525	Decal, Danger	1
3	323232	Decal, Instructional	1	16	413214	Decal, Tracking	1
4	323151	Decal, Throttle/Choke (Kawasaki & Kohler)	1	17	603845	Decal, Drive Wheel Release	1
5	543631	Decal, Throttle (B&S)	1	18	613169	Decal, Shifter	1
6	303517	Decal, Belt Drive	1	19	303102	Decal, Neutral Lock Label	2
7	303508	Decal, Discharge Warning	1	20	403132	Decal, Commercial "52"	1
8	303520	Decal, TriVantage	1	21	323411	Decal, Commercial "36"	1
9	323141	Decal, Mower Engagement	1	22	403131	Decal, Commercial "48"	1
10	323321	Decal, Small Viking	1	23	403143	Decal, Sully warning	1
11	513746	Decal, Muffler	1	24	323427	Decal, Belt routing (36" Deck)	1
12	303293	Decal, Caution	1	25	403139	Decal, Belt routing (48"&52")	1
13	403005	Decal, Danger (36")	1	26	403080	Decal, Patent No.	1
	403005	Decal, Danger (48"& 52")	2	27	323540	Decal, Roller Mounting (52")	1

UPPER HANDLES and CONTROLS

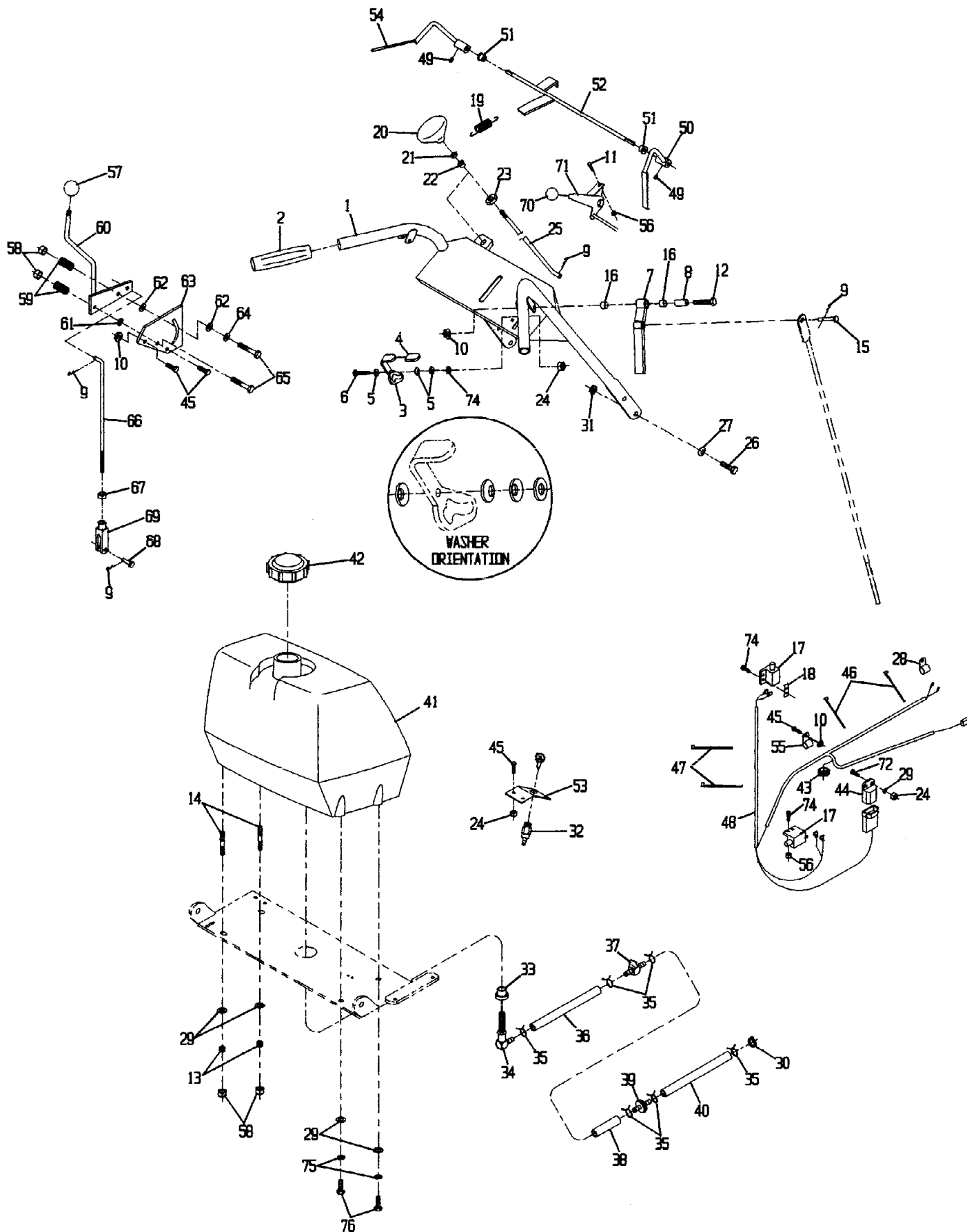

UPPER HANDLES and CONTROLS

Ref. No.	Part No.	Description	Qty. Req'd.	Ref. No.	Part No.	Description	Qty. Req'd.
1	322197	Handle weldment.....	1	39	303197	Filter, gas	1
2	303097	Grip, handle.....	2	40	603954	Gas line, 13.75" (Kohler).....	1
3	612168	Latch, thumb w/grip (RH)	1		303471	Gas line, 12.0" (Kaw)	1
<i>f</i>	612167	Latch, thumb w/grip (LH)	1	41	413179	Tank, gas	1
4	303019	Grip, latch.....	2	42	513508	Cap, gas.....	1
5	303435	Washer, 1/4 spring disc.....	6	43	543296	Grommet.....	1
6	800257	Screw, 1/4-20 x 1-3/4	2	44	323430	Module, Interlock.....	1
<i>f</i>	412159	Lever, drive (LH).....	1	45	800251	Screw, 1/4-20 x 5/8	
7	412161	Lever, drive (RH).....	1			(Kaw & Kohler).....	3
8	603749	Bushing, drive lever.....	2		800251	Screw, 1/4-20 x 5/8 (B&S)	5
9	806003	Hairpin	5	46	303287	Tie, plastic 5 1/2" (Kaw)	5
10	809012	Nut, whizlock 1/4-20.....	5		303287	Tie, plastic 5 1/2"(Koh&Briggs)	4
11	807513	Screw, #10-24 x 1/2 carriage ...	2	47	303335	Tie, plastic 7 5/16".....	2
12	800256	Screw, 1/4-20 x 1-1/2	2	48	323518	Harness wiring (Kawasaki)	1
13	633349	Spring, fuel tank	2		323519	Harness wiring (Kohler)	1
14∇	633023	Stud, fuel tank	2		403147	Harness wiring (B&S).....	1
15	613055	Pin, clevis	2	49♦	803322	Setscrew, 5/16-24 x 5/16	2
16	413152	Bearing	4	50∇	412185	Lever, OPC (RH).....	1
17	513051	Switch	2	51	303365	Bushing, nylon.....	2
18	633181	Plate, tapped	1	52	322192	Rod weldmt, connecting.....	1
19	303363	Spring, actuator.....	1	53	403118	Bracket, key switch (B&S).....	1
20	323134	Knob, (push/pull)	1	54∇	412183	Lever, OPC (LH)	1
21	804751	Nut, jam 5/16-18.....	1	55	603727	Clip, .56 Loom.....	1
22	323143	Bushing, nylon .38 I.D.	1	56	804252	Nut, nylock #10-24	4
23	323142	Push Nut (.50 shaft)	1	57♦	603175	Knob, 1-3/8.....	1
24	804255	Nut, nylock 1/4-20		58	804256	Nut, nylock 5/16-18.....	4
		(Kaw & Koh)	3	59	323245	Spring, compression	2
	804255	Nut, nylock 1/4-20 (B&S).....	5	60	602733	Lever, shift	1
25	323181	Linkage, blade push/pull.....	1	61	805257	Washer, 5/16 (sae)	1
26	800292	Screw, 3/8-16 x 1	4	62	323244	Washer, friction	2
27	303327	Washer, 3/8 spring disc.....	4	63	603730	Plate, shift lever.....	1
28	323229	Clip, loom 3/8" (Kaw).....	1	64	603716	Washer, friction	1
29	805256	Washer 1/4" std flat.....	5	65	800277	Screw, 5/16-18 x 2	2
30	303308	Clamp, gas line (Kawasaki)....	1	66	323522	Rod, speed control.....	1
31	809007	Nut, whizlock 3/8-16	4	67	804758	Nut, jam 5/16-24.....	1
32	403121	Switch, ON-Off key (B&S)	1	68	808280	Pin, clevis.....	1
	603511	Keys, ignition	1	69	303105	Yoke, adjustable.....	1
33	513645	Bushing, fuel valve	1	70	513592	Knob, red ball.....	1
34	543277	Elbow, fuel tank.....	1	71	323129	Cable, throttle (Kaw & Kohler).	1
35	303077	Clamp, gas line (Kohler).....	6		543697	Cable, throttle (B&S).....	1
	303077	Clamp, gas line (B&S).....	4	72	800252	Screw, 1/4-20 x 3/4	1
	303077	Clamp, gas line (Kawasaki)....	5	73	801040	Screw, #10-24 x .75.....	2
36	603955	Fuel line, 6" (Kaw & Kohler) ...	1	74	803028	Screw, #10-24 x 5/8	4
	543649	Fuel line, 7" (B&S).....	1	75	805005	Washer, 5/16 lock	2
37	603770	Valve, gas.....	1	76	800271	Screw, 5/16-18 x 3/4	2
38	603776	Fuel line, 2.5" (Kaw & Kohler)	1				
	303471	Fuel line, 12" (B&S).....	1				

f Not Illustrated.

♦ Use Pro-Lock ,nut type (Part no. 840022 on setscrew threads and on shifter knob threads.

∇ Use Pro-lock, retaining type (Part no. 840023 .5cc tube) on inside bore of OPC hub and on fuel tank studs.

Apply dielectric grease on all electrical connectors.

Exmark black touch up spray paint - Gloss black

HYDRAULICS GROUP

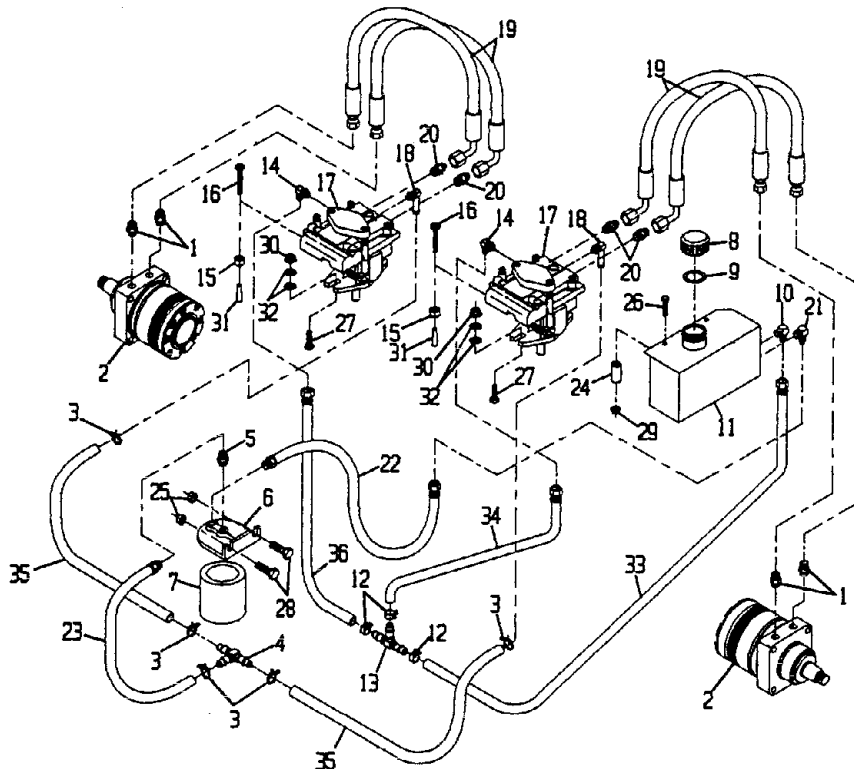

Ref. No.	Part No.	Description	Qty. Req'd.	Ref. No.	Part No.	Description	Qty. Req'd.
1	603991	Fitting, strght connector.....	4	17	613042	Pump, hydro.....	2
	603919	Boss O-Ring.....	1	18	603989	Elbow, 90°.....	2
	603992	Flare O-Ring.....	1		603923	O-Ring.....	1
2	603718	Wheel motor.....	2	19	403102	Hose, high pressure.....	4
	000138	Kit, Bearing.....	1	20	603990	Adapter, straight thread.....	4
	000119	Kit, seal.....	1		603920	Boss O-Ring.....	1
3	603827	Clamp, hose (5/8).....	5		603992	Flare O-Ring.....	1
4	603721	Fitting, Hose Tee (3/8 I.D hose)	1	21	603988	Elbow, 90°.....	1
5	513510	Connector, male.....	1	22	602985	Hose, supply.....	1
6*	603720	Head, filter.....	1	23	602754	Hose, charge line.....	1
7	513211	Element, oil filter.....	1	24	323218	Spacer, hydraulic tank.....	2
∇	523541	Element, oil filter(winter).....	1	25	809001	Nut, whizlock 5/16-18.....	2
8	513167	Cap, hydraulic reservoir.....	1	26	800258	Screw, 1/4-20 x 2.....	2
9	523103	Gasket, tank cap.....	1	27	800293	Screw, 3/8-16 x 1-1/4.....	4
10	603987	Elbow, 90°.....	1	28	800273	Screw, 5/16-18 x 1.....	2
11*	512166	Reservoir, hydraulic fluid.....	1	29	809012	Nut, whizlock 1/4-20.....	2
12	603826	Hose Clamp 1/2.....	3	30	809007	Nut, whizlock 3/8-16.....	4
13	603722	Fitting - Hose Tee(1/4 I.D hose)	1	31	613073	Grip, dump valve.....	2
14	513840	Elbow - 90°.....	2	32	805258	Washer, 5/16 std.....	8
	603921	O-Ring.....	1	33	602750	Hose, case drain.....	1
15	804255	Nut, nylock 1/4-20.....	2	34	632286	Hose assy, lo pressure.....	1
16	801063	Screw, 1/4-20 x 2 pan head ...	2	35	413273	Hose, lo pressure.....	2
				36	632285	Hose assy, lo pressure.....	1

* Use Teflon Pipe Sealant or equivalent on hydraulic reservoir and filter head fittings.

∇ Use only for operation below 32°F(0°C)

Emark black touch up spray paint - gloss black

WIRING DIAGRAMS

B&S VANGUARD

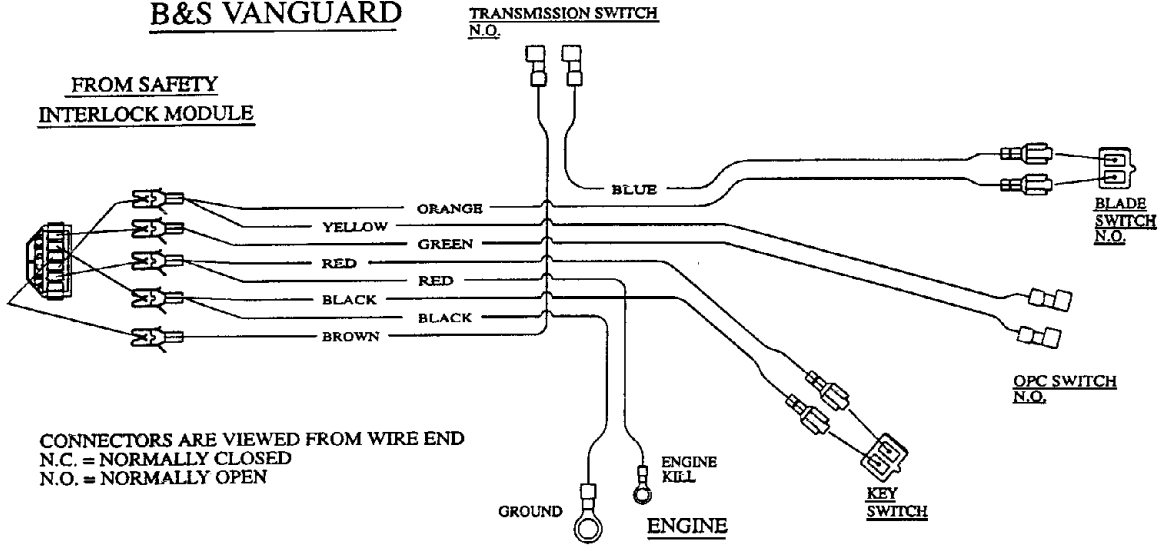

KAWASAKI

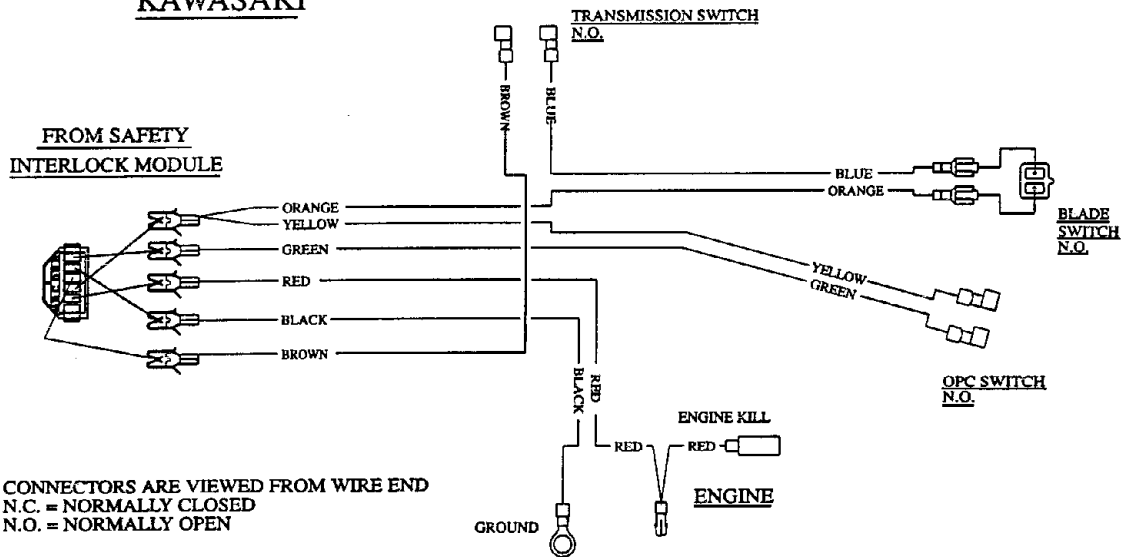

KOHLER

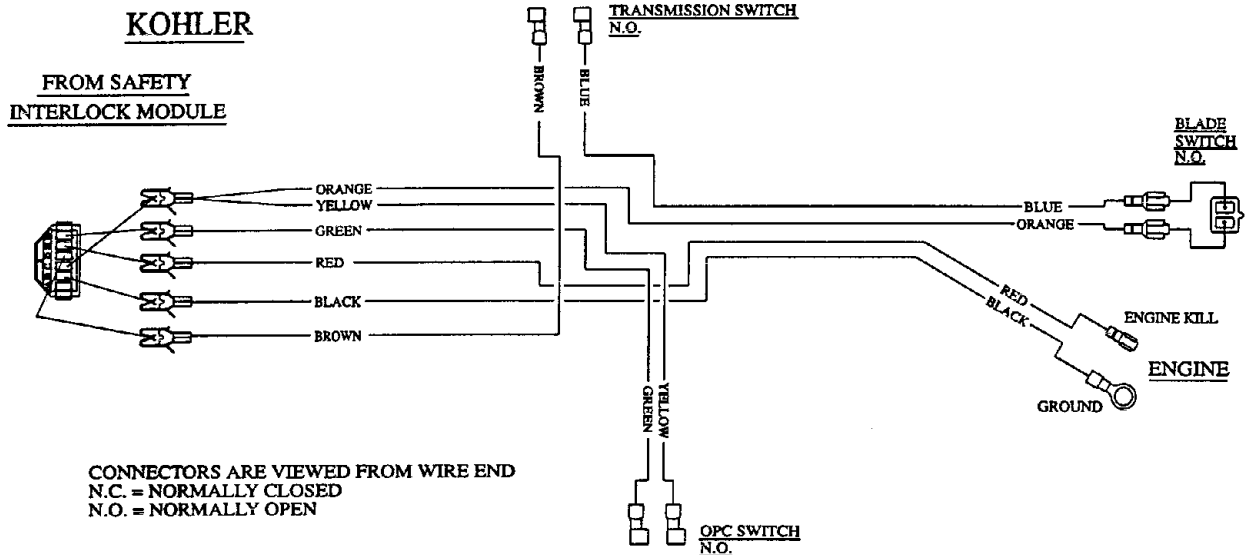

**SEE EXMARK'S COMPLETE
LINE OF PRODUCTS FOR TURF CARE**

LAZER Z

EXPLORER

TURF RANGER

TURF TRACER HYDRO

TURF TRACER HP

VIKING 5-SPEED

VIKING HYDRO

METRO

SELF STEERING SULKY

GRASS CATCHER

MICRO-MULCHING ACCESSORY

**EXMARK MFG. CO. INC.
INDUSTRIAL PARK BOX 808
BEATRICE, NE. 68310**

**PART NO. 850436
(402) 223-4010
FAX (402) 223-4154**

ALL RIGHTS RESERVED

PRINTED IN U.S.A.

