



M216H/ M216HSP

For Serial Nos. 370,000 & Higher



OPERATOR'S MANUAL

METRO™ 21

CONGRATULATIONS on the purchase of your new Exmark mower. This product has been carefully designed and manufactured to give you a maximum amount of dependability and years of trouble-free operation. If additional information is needed, or should you require trained mechanic service, contact your authorized Exmark equipment dealer or distributor. If you need to order replacement parts from your dealer, always give the model number and serial number of your mower as well as the part number, description and quantity of the part needed.

The Serial No. plate is located on the top of the mower deck on the right hand corner of the machine. For ease of ordering and reference, we suggest that you record the information requested in the following identification table.

Place Model No. and Serial No. Label Here
(Included in Literature Pack)
or Fill in Below

Model No. _____

Serial No. _____

Engine Model No. and Spec. No. (Code) _____

Engine Serial No (E/No) _____

Date Purchased _____

IMPORTANT

When the mower is used or operated on any California forest-, brush- or grass-covered land, a working spark arrester must be attached to the muffler. If not, the operator is violating state law, Section 4442 Public Resource Code. To acquire a spark arrester for your unit, see your Engine Service Dealer.



WARNING



POTENTIAL HAZARD

- This product is a piece of power equipment.

WHAT CAN HAPPEN

- Failure to follow safe operating practices can result in serious operator injury or even death.

HOW TO AVOID THE HAZARD

- Keep all shields, guards, and safety devices (especially the grass discharge system) in place and in proper working condition.
- Before adjusting, servicing, or performing maintenance, stop the engine and wait for all moving parts to stop, then remove the spark plug wire or remove the key.
- If the mower deck becomes clogged, stop the engine and wait for all moving parts to stop, then remove the spark plug wire or remove the key before cleaning the blockage.
- Keep hands, feet, and clothing away from power-driven parts.
- Keep off the mower unless the seat platform is provided.
- Keep others off the mower.



WARNING



POTENTIAL HAZARD

- Gasoline is harmful or fatal if swallowed. Long-term exposure to vapors has caused cancer in laboratory animals.

WHAT CAN HAPPEN

- Failure to use caution may cause serious injury or illness.

HOW TO AVOID THE HAZARD

- Avoid prolonged breathing of vapors.
- Keep face away from nozzle and gasoline tank/container opening.
- Keep gasoline away from eyes and skin.
- Never siphon gasoline by mouth.

Exmark reserves the right to make changes to add improvements to its products at any time without incurring any obligation to make such changes to products manufactured previously. Exmark, or its distributors and dealers, accept no responsibility for variations which may be evident in the actual specifications of its products and the statements and descriptions contained in this publication.

EXMARK PARTS PLUS[®] PROGRAM

EFFECTIVE DATE: September 1,1995

Program

If your Exmark dealer does not have the Exmark part in stock, Exmark will get the parts to the dealer the next business day or the part will be FREE* Guaranteed!!

How the Program Works

1. If dealer does not have part in stock for a "down" unit at the time of request by customer, the dealer contacts his distributor by 1:00 p.m. local time, and requests Exmark Parts Plus[®] shipment of six line items or less.
2. Distributor ships part(s) to dealer or customer, as requested by dealer, same day, overnight UPS. Distributor bills dealer for part and freight charges where applicable.
3. If distributor does not have the part(s) in stock to satisfy Exmark Parts Plus[®] order, he contacts Exmark by 3:00 p.m., central time, with an Exmark Parts Plus[®] order of six line items or less.
4. If order is received by 3:00 p.m. central time, Exmark ships part(s) direct to dealer or customer, as requested by distributor, same day, overnight UPS, Exmark bills the distributor for parts and shipping charges, where applicable.
5. The customer pays for the part and freight if it is shipped under the Exmark Parts Plus[®] and if it arrive in accordance to the program.
6. Who pays for the part and freight if it fails to arrive overnight in accordance to the program?
 - A. Under any circumstance the customer does not pay.
 - B. If the part does not arrive overnight due to:
 1. The dealer not submitting the Exmark Parts Plus[®] order to his Exmark distributor by 1:00 p.m., the dealer pays for the part and freight.
 2. The Distributor being unable to ship the part the same day or not submitting the Exmark Parts Plus[®] order to Exmark by 3:00 p.m. central time, the Distributor pays for the part and freight.
 3. Exmark being unable to ship the part and the Exmark parts order is received by 3:00 p.m. central time, Exmark pays for the part and freight.
 4. If the part does not arrive overnight due to the shipper (UPS), the shipper pays for the freight and Exmark pays for the part.

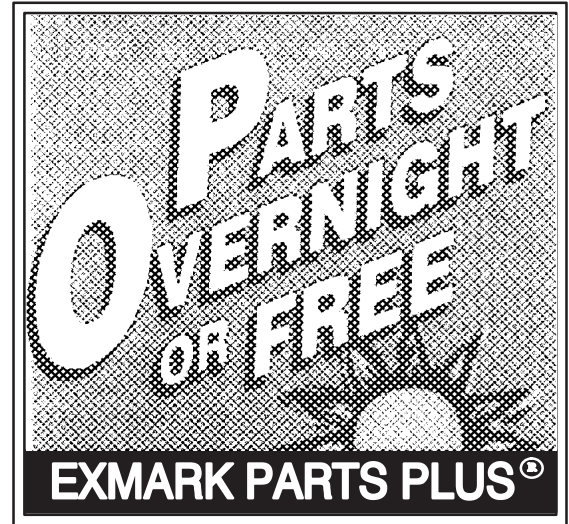

The following restrictions apply — The Exmark Parts Plus[®] Program is available only through participating Exmark Dealers and applies only to orders submitted on this program Monday through Thursday. Parts Plus service is available only in the 48 contiguous United States. UPS has initiated a Saturday delivery program to many areas of the continental United States and can be requested for an overnight shipment on Friday to be delivered Saturday. The next day air charge, plus the Saturday delivery fee will be the responsibility of the purchaser. Exmark Mfg. will assume no responsibility for Saturday delivery shipments. To qualify, all Exmark Parts Plus[®] orders must be received by Exmark by 3:00 p.m. central time. Orders must be six line items or less. Exclusions from the Exmark Parts Plus[®] Program are: Any wholegood or accessory in its entirety, engines and engine replacement parts, 5-speed Peerless transmissions and 5-speed transaxles, hydraulic or hydrostatic wheel motors, cutter decks and engine decks or any item exceeding United Parcel Service size and weight restrictions.

Due to UPS restrictions, aerosol spray paint is considered a hazardous material and cannot be shipped via UPS next day or Second Day Air.

Exmark Manufacturing stocks a limited supply of parts for transaxles, pumps and wheel motors. These parts can be ordered for Next Day Air shipment but will not be guaranteed per the Parts Plus Program.

CONGRATULATIONS on the purchase of your Exmark Mower. This product has been carefully designed and manufactured to give you a maximum amount of dependability and years of trouble-free operation.

OPERATOR'S MANUAL

This manual contains assembly, operating, maintenance, adjustment and safety instructions for your Exmark mower.

BEFORE OPERATING YOUR MOWER, CAREFULLY READ THIS MANUAL IN ITS ENTIRETY.

By following the operating, maintenance and safety instructions, you will prolong the life of your mower, maintain its maximum efficiency and promote safe operation.

If additional information is needed, or should you require trained mechanic service, contact your authorized Exmark equipment dealer or distributor.

All Exmark equipment dealers and distributors are kept informed of the latest methods of servicing and are equipped to provide prompt and efficient service in the field or at their service stations. They carry ample stock of service parts or can secure them for you from the factory.

All Exmark parts are thoroughly tested and inspected before leaving the factory; however, attention is required on your part if you are to obtain the fullest measure of satisfaction and performance.

This spark ignition system complies with Canadian ICES-002.

Ce système d'allumage par étincelle de véhicule est conforme à la norme NMB-002 du Canada.

The enclosed Engine Owner's Manual is supplied for information regarding The U.S. Environmental Protection Agency (EPA) and the California Emission Control Regulation of emission systems, maintenance and warranty.

Keep this engine Owner's Manual with your unit. Should this engine Owner's Manual become damaged or illegible, replace immediately. Replacements may be ordered through the engine manufacturer.

Contents

	Page
Specifications	1
Introduction	2
Safety	2
Safe Operating Practices	2
Exmark Lawn Mower Safety	3
Safety and Instruction Decals	4
Assembly	5
Loose Parts	5
Installing the Handle	6
Installing the Starter Rope	6
Installing the Discharge Tunnel Plug	6
Before Starting	7
Filling the Crankcase with Oil	7
Filling the Fuel Tank with Gasoline	7
Reviewing the Maintenance Schedule	8
Operation	9
Controls	9
Starting the Engine	9
Stopping the Engine	9
Using the Self-propel Drive	10
Using the Discharge Tunnel Plug	10
Adjusting the Cutting Height	10
Using the Grass Bag	11
Operating Tips	12
Maintenance	14
Recommended Maintenance Schedule	14
Checking the Engine Oil Level	15
Cleaning under the Housing	15
Cleaning the Discharge Tunnel and Plug	16
Servicing the Air Cleaner	16
Maintaining the Blade	17
Cleaning under the Belt Cover	18
Lubricating the Pivot Arms	19

	Page
Adjusting the Self-propel Drive	19
Changing the Engine Oil	19
Servicing the Spark Plug	20
Lubricating the Gear Case	20
Adjusting the Blade Brake Cable	20
Servicing the Wheels	21
Storage	22
Preparing the Fuel System	22
Preparing the Engine	22
General Information	22
Removing the Lawn Mower from Storage	22
Accessories	22
Troubleshooting	23
Limited Warranty	
Exmark Commercial Turf Equipment	26

Specifications

Model Number:	M216H, M216HSP
Engine:	Honda 5.5 HP OHV 3350 RPM (No load)
Fuel System:	
Capacity:	2.1 qt. (2.0 L)
Transmission (M216HSP):	
3 speeds forward	
Speed range:	
First	2.2 mph (3.5 km/h)
Second	3.2 mph (5.2 km/h)
Third	4.5 mph (7.3 km/h)
Cutting Width:	21 in. (53 cm)
Cutting Height:	
Adjusts in 0.5 in. (1.3 cm) increments from	
.75 in. (1.9 cm) to 3.25 in. (8.3 cm)	
Grass Catcher Capacity	2.5 Bu. (88 L)
Weight (with bag):	
M216H	96 lb. (44 kg)
M216HSP	108 lb. (49 kg)

Introduction

Read this manual carefully to learn how to operate and maintain your product properly. The information in this manual can help you and others avoid injury and product damage. Although Exmark designs and produces safe products, you are responsible for operating the product properly and safely.

This manual identifies potential hazards and has special safety messages that help you and others avoid personal injury and even death. **Danger**, **Warning**, and **Caution** are signal words used to identify the level of hazard. However, regardless of the hazard, be extremely careful.

Danger signals an extreme hazard that *will* cause serious injury or death if you do not follow the recommended precautions.



Warning signals a hazard that *may* cause serious injury or death if you do not follow the recommended precautions.

Caution signals a hazard that may cause minor or moderate injury if you do not follow the recommended precautions.

This manual uses two other words to highlight information. **Important** calls attention to special mechanical information and **Note** emphasizes general information worthy of special attention.

Safety

This lawn mower meets or exceeds the CPSC blade safety requirements for walk-behind rotary lawn mowers and the B71.4 specifications of the American National Standards Institute in effect at the time of production.

 Warning 
<p>Engine exhaust contains carbon monoxide, an odorless, deadly poison that can kill you.</p> <p>Do not run the engine indoors or in an enclosed area.</p>

To ensure maximum safety and best performance, and to gain knowledge of the product, it is essential that you and any other operator of the lawn mower read and understand the contents of this manual before the engine is ever started.

 This is the safety alert symbol. It is used to alert you to potential personal injury hazards. Obey all safety messages that follow this symbol to avoid possible injury or death.

Improperly using or maintaining this lawn mower could result in injury or death. To reduce this potential, comply with the following safety instructions.

Safe Operating Practices

The following instructions are from the ANSI/OPEI B71.4-1999 standard.

Training

- Read the Operator's Manual and other training material. If the operator(s) or mechanic(s) can not read English it is the owner's responsibility to explain this material to them.
- Become familiar with the safe operation of the equipment, operator controls, and safety signs.
- All operators and mechanics should be trained. The owner is responsible for training the users.
- Never let children or untrained people operate or service the equipment. Local regulations may restrict the age of the operator.
- The owner/user can prevent and is responsible for accidents or injuries occurring to themselves, other people, or property.

Preparation

- Only use accessories and attachments approved by the manufacturer.
- Wear appropriate clothing including hard hat, safety glasses, and ear protection. Long hair, loose clothing or jewelry may get tangled in moving parts.
- Inspect the area where the equipment is to be used and remove all objects such as rocks, toys and wire which can be thrown by the machine.
- Use extra care when handling gasoline and other fuels. They are flammable and vapors are explosive.
 - Use only an approved container.
 - Never remove gas cap or add fuel with engine running. Allow engine to cool before refueling. Do not smoke.
 - Never refuel or drain the machine indoors.
- Check that operator's presence controls, safety switches and shields are attached and functioning properly. Do not operate unless they are functioning properly.

Operation

- Never run an engine in an enclosed area.
- Only operate in good light, keeping away from holes and hidden hazards.
- Only start engine from the operator's position.
- Be sure of your footing, especially when backing up. Walk, don't run. Never operate on wet grass. Reduced footing could cause slipping.

- Slow down on hillsides. Be sure to travel side to side on hillsides. Turf conditions can affect the machine's stability. Use caution while operating near drop-offs.
- Do not change the engine governor setting or overspeed the engine.
- Stop on level ground and shut off engine before leaving the operator's position for any reason including emptying the catcher or unclogging the chute.
- Stop equipment and inspect blade after striking objects or if an abnormal vibration occurs. Make necessary repairs before resuming operations.
- Keep hands and feet away from the cutting units.
- Look behind and down before backing up to be sure of a clear path.
- Keep pets and bystanders away.
- Slow down and use caution when crossing roads and sidewalks.
- Stop blade if you are not mowing.
- Be aware of the mower discharge direction and do not point it at anyone.
- Do not operate the mower under the influence of alcohol or drugs.
- Use care when approaching blind corners, shrubs, trees, or other objects that may obscure vision.
- Do not operate the lawn mower without either the grass catcher or the guard in place.
- Keep all parts in good working condition and all hardware tightened. Replace all worn or damaged decals.

Exmark Lawn Mower Safety

The following list contains safety information specific to Exmark products or other safety information that you must know that is not included in the ANSI/OPEI standard.

This product is capable of amputating hands and feet, and of throwing objects. Always follow all safety instructions to avoid serious injury or death.

Use this product only for cutting and mulching grass, or, when equipped with a grass bagger, for catching cut grass.

- Stop the lawn mower if anyone enters the area.
- Do not operate the lawn mower without either the grass catcher or the guard in place.
- Do not touch the lawn mower or attachment parts which may be hot from operation. Allow the lawn mower to cool down before attempting to maintain, adjust, or service it.

Maintenance and Storage

- Stop engine and disconnect spark plug wire. Wait for all movement to stop before adjusting, cleaning or repairing.
- Clean grass and debris from cutting unit, drive, muffler, and engine to help prevent fires. Clean up oil or fuel spillage.
- Let engine cool before storing and do not store near flame.
- Shut off fuel while storing or transporting. Do not store fuel near flames or drain indoors.
- Never allow untrained personnel to service machine.
- Remove spark plug wire before making any repairs.
- Use care when checking blade. Wrap the blade or wear gloves, and use caution when servicing them. Only replace blade. Never straighten or weld it.
- Keep hands and feet away from moving parts. If possible, do not make adjustments with the engine running.

Safety and Instruction Decals



Safety decals and instructions are easily visible to the operator and are located near any area of potential danger. Replace any decal that is damaged or lost.

TRACTION CONTROL	OPERATING INSTRUCTIONS START: 1. MOVE GROUND SPEED CONTROL TO N 2. MOVE THROTTLE TO FAST. 3. LIFT CONTROL BAR TO HANDLE AND HOLD. 4. PULL ROPE WHEN ENGINE STARTS REGULATE THROTTLE AS DESIRED. STOP: RELEASE CONTROL BAR.	DRIVE RUN OFF E213042	WARNING	READ YOUR OPERATOR'S MANUAL FOR OPERATING AND SAFETY INSTRUCTIONS. TO GET A REPLACEMENT MANUAL, SEND MODEL AND SERIAL NUMBERS TO: EXMARK MANUFACTURING CO. P.O. BOX 808 BEATRICE, NE 68310
-------------------------	--	--------------------------------	----------------	---

1-213242 (Self-propel model only)



39-5770



74-1970 (Self-propel model only)

1. Transmission speeds 2. Neutral



77-0500

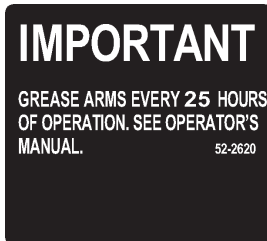

52-2610 (Hand-push model only)



82-9152

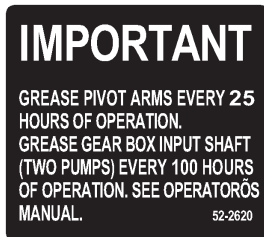

52-2620 (Self-propel model only)

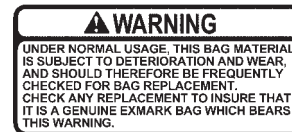

98-8017



68-7410



104-1329

WARNING

AVOID SERIOUS INJURY or DEATH:

- GO ACROSS SLOPES, NOT UP AND DOWN.
- DO NOT MOW WHEN CHILDREN OR OTHERS ARE AROUND.
- DO NOT ALLOW OPERATION OF THIS MACHINE BY UNTRAINED PERSONNEL.
- KEEP SAFETY DEVICES (GUARDS, SHIELDS, ETC.) IN PLACE AND WORKING.
- REMOVE OBJECTS THAT COULD BE THROWN BY THE BLADE.
- READ THE OPERATOR'S MANUAL.

FOR REPLACEMENT MANUAL, SEND MODEL & SERIAL NUMBER TO:
EXMARK MFG. CO., P.O. BOX 808, BEATRICE, NEBRASKA 68310

104-8585

Assembly

Note: Determine the left and right sides of the machine from the normal operating position.

Loose Parts

DESCRIPTION	QTY.	USE
Handle	1	Installing the handle
Bolts, 5/16–18 x 1-1/4 in.	2	
Bolts, 5/16–18 x 1-1/2 in.	2	
Carriage bolt	1	
Washers	4	
Locknuts	2	
Thin nylon insert locknuts	2	
Bag support rod	1	
Bag aligning plate	1	
Cap locknuts	3	
Cable tie	1	

Installing the Handle

1. Mount the handle to the outside of the lawn mower housing (using the bottom hole) with two 5/16–18 x 1–1/4 in. bolts, washers, and thin nylon insert locknuts (Fig. 1).

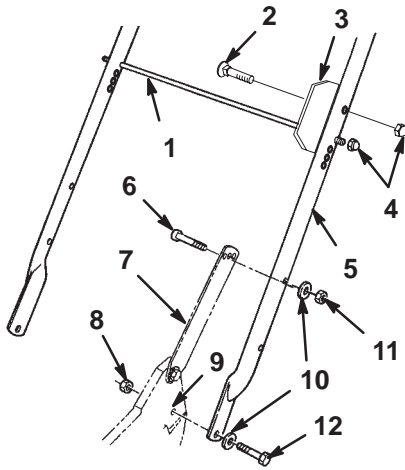

Figure 1

- | | |
|--------------------------------|---------------------------------|
| 1. Bag support rod | 7. Handle latch (2) |
| 2. Carriage bolt | 8. Locknut (2) |
| 3. Bag aligning plate | 9. Bottom hole in housing |
| 4. Cap locknuts (3) | 10. Washer (4) |
| 5. Handle | 11. Locknut (2) |
| 6. Bolt, 5/16–18x1-1/4 in. (2) | 12. Bolt, 5/16–18x1-1/2 in. (2) |

2. Secure the handle latches to the handle with two 5/16–18 x 1-1/2 in. bolts, washers, and nylon insert locknuts (Fig. 1).

Note: You can adjust the handle height for comfortable operation. Stand behind the handle to determine the height. To adjust the handle height, position the bolts and the locknuts that secure the handle latches to the handle into the other mounting holes in the handle latches.

3. Slide the bag support rod through the bag aligning plate and into the second from the top mounting holes in the handle, and secure each end with a cap locknut (Fig. 1).
4. Insert the carriage bolt through the bag aligning plate and the top hole on the left side of the handle, and secure it with a cap locknut (Fig. 1).
5. Use a cable tie to secure the control cables to the left handle below the bag support rod.

Installing the Starter Rope

Pull the starter rope through the rope guide on the handle (Fig. 2).

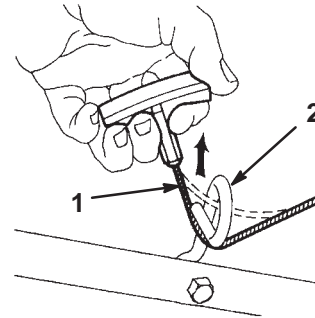

Figure 2

- | | |
|-----------------|---------------|
| 1. Starter rope | 2. Rope guide |
|-----------------|---------------|

Note: To make the rope easier to install, squeeze the control bar on the handle.

Installing the Discharge Tunnel Plug

1. Open the discharge door by pulling forward on the handle and moving it rearward (Fig. 3). Hold the discharge door handle to prevent the spring-loaded door from closing while you insert the plug.

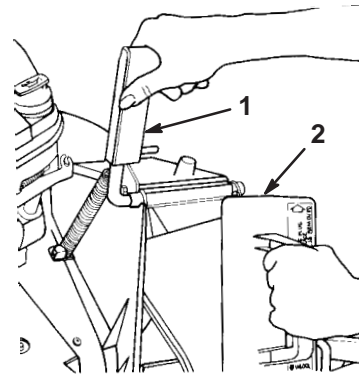

Figure 3

- | | |
|--------------------------|---------------------------|
| 1. Discharge door handle | 2. Plug rotated clockwise |
|--------------------------|---------------------------|

2. Since the plug is slightly wider than the discharge tunnel opening, rotate the plug clockwise slightly while inserting it (Fig. 3).

Note: Ensure that the arrow on the plug decal points upward.

3. Push the plug all the way in until the spring clip on the bottom of the plug clicks into place, locking the plug securely into the discharge tunnel (Fig. 4).

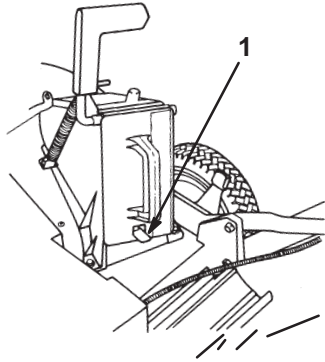

Figure 4

m-275

1. Spring clip

4. Release the discharge door handle to lock the top of the plug.

Before Starting

Filling the Crankcase with Oil

The engine crankcase can hold 22 ounces (0.65 liters) of oil. Use only high-quality SAE 10W-30 weight detergent oil that has the American Petroleum Institute (API) service classification SH, SJ, or equivalent.

Before each use, ensure that the oil level is between the lower limit and upper limit marks on the dipstick (Fig. 5).

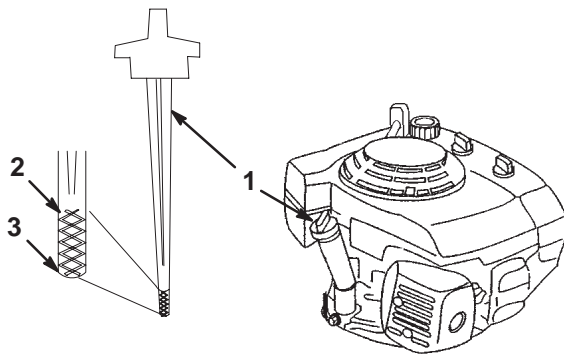

Figure 5

1. Dipstick
2. Upper limit mark
3. Lower limit mark

Note: When the crankcase is empty, pour about three-fourths of the crankcase capacity of oil in the crankcase, then follow the procedure in this section.

To add oil:

1. Move the lawn mower to a level surface.
2. Clean around the dipstick (Fig. 5).
3. Remove the dipstick by rotating the cap counterclockwise and pulling it out.
4. Wipe the dipstick clean with a clean cloth.
5. Insert the dipstick into the filler neck (but **do not rotate the cap clockwise to secure it**), then remove it.
6. Read the oil level on the dipstick (Fig. 5).
7. If the oil level reading is below the lower limit mark on the dipstick, remove the dipstick and **slowly** pour only enough oil into the filler hole to raise the oil level to the upper limit mark on the dipstick (Fig. 5).

Important Do not overfill the crankcase with oil and run the engine; engine damage will result. Drain the excess oil until the oil level reaches the upper limit mark on the dipstick.

8. Insert the dipstick into the filler neck and rotate the cap clockwise until it is tight.

Filling the Fuel Tank with Gasoline

For best results, use clean, fresh, lead-free gasoline with an octane rating of 87 or higher. To ensure freshness, purchase only the quantity of gasoline that you expect to use in 30 days. Using unleaded gasoline results in fewer combustion deposits and longer engine life.

Important Do not add oil to the gasoline.

Important Do not use methanol, gasoline containing methanol, gasohol containing more than 10% ethanol, premium gasoline, or white gas. Using these fuels can damage the engine's fuel system.

Important Do not use gasoline that is more than 30 days old.



Danger



In certain conditions, gasoline is extremely flammable and highly explosive. A fire or explosion from gasoline can burn you and others and can damage property.

- Fill the fuel tank outdoors, in an open area, and when the engine is cold. Wipe up any gasoline that spills.
- Do not fill the fuel tank completely full. Add gasoline to the fuel tank until the level is 1/4 to 1/2 in. (6 to 13 mm) below the bottom of the filler neck. This empty space in the tank allows the gasoline to expand.
- Never smoke when handling gasoline, and stay away from an open flame or where a spark may ignite the gasoline fumes.
- Store gasoline in an approved fuel container and keep it out of the reach of children.
- Never buy more than a 30-day supply of gasoline.



Danger



When fueling, under certain circumstances, a static charge can develop, igniting the gasoline. A fire or explosion from gasoline can burn you and others and damage property.

- Always place gasoline containers on the ground and away from your vehicle before filling.
- Do not fill gasoline containers inside a vehicle or on a truck or trailer bed because interior carpets or plastic truck bed liners may insulate the container and slow the loss of any static charge.
- When practical, remove gasoline-powered equipment from the truck or trailer and refuel the equipment with its wheels on the ground.
- If this is not possible, then refuel such equipment on a truck or trailer from a portable container, not from a gasoline dispenser nozzle.
- If you must use a gasoline dispenser nozzle, keep the nozzle in contact with the rim of the fuel tank or container opening at all times until fueling is complete.

Use a fuel stabilizer/conditioner regularly during operation and storage. A fuel stabilizer/conditioner cleans the engine during operation and prevents gum-like varnish deposits from forming in the engine during periods of storage.

Important Do not use fuel additives other than a fuel stabilizer/conditioner. Do not use fuel stabilizers with an alcohol base such as ethanol, methanol, or isopropanol.

1. Clean around the fuel tank cap (Fig. 6).

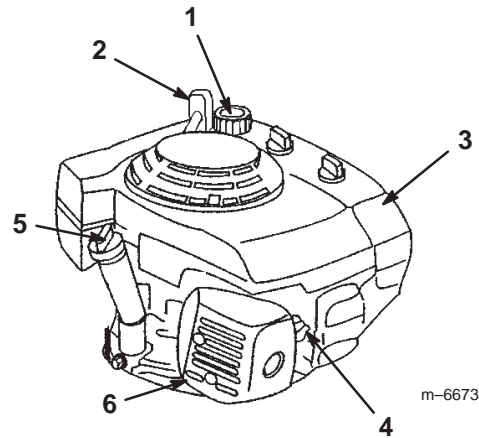

Figure 6

- | | |
|--------------------------|--------------------------------|
| 1. Fuel tank cap | 4. Spark plug |
| 2. Recoil starter handle | 5. Dipstick/Oil fill and drain |
| 3. Air cleaner | 6. Muffler |

2. Remove the fuel tank cap.

3. Fill the fuel tank with unleaded gasoline to within 1/4 to 1/2 inch (6 to 13 mm) from the top of the tank. **Do not fill into the filler neck.**

Note: The fuel tank capacity is 2.1 qt. (2.0 l).

Important Do not fill the tank more than 1/4 inch (6 mm) from the top of the tank because the gasoline must have room to expand.

4. Install the fuel tank cap and wipe up any spilled gasoline.

Reviewing the Maintenance Schedule

Review the Recommended Maintenance Schedule on page 14. You may need to perform one or more additional procedures before or soon after you begin operating the lawn mower.

Operation

Note: Determine the left and right sides of the machine from the normal operating position.

Each time before you mow, ensure that the self-propel drive and the control bar operate properly. When you release the control bar, the engine and the blade should stop within 3 seconds. If they do not, contact an Authorized Service Dealer.

Caution

This machine produces sound levels in excess of 85dBA at the operator's ear and can cause hearing loss through extended periods of exposure.

Wear hearing protection when operating this machine.

Controls

The control bar, the throttle control, and the starter handle are on the upper handle as shown in Figure 7.

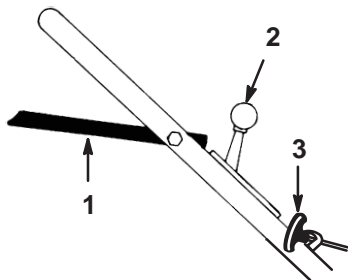

Figure 7

- 1. Control bar
- 2. Throttle
- 3. Starter handle

Starting the Engine

1. Connect the wire to the spark plug (Fig. 6).
2. Open the fuel valve by moving the lever to the **right** (Fig. 8).

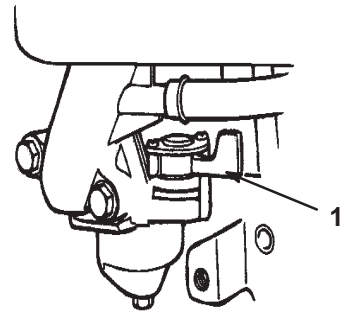

Figure 8

- 1. Fuel valve

3. Move the throttle control to the **Choke** position (Fig. 7).

Note: Do not use the choke when the engine is warm.

4. Hold the control bar to the handle (Fig. 7).
5. Pull the starter handle (Fig. 7) lightly until you feel resistance, then pull it sharply. Allow the rope to return to the handle slowly.
6. When the engine starts, move the throttle control to the **Fast** position, and set the ground speed control as desired.

Note: If the engine fails to start after three pulls, repeat steps 4 through 6.

Stopping the Engine

Release the control bar. Both the engine and the blade should stop within 3 seconds. If they do not, contact an Authorized Service Dealer.

Note: Close the fuel valve by moving the lever to the **left** if you will not be starting the engine soon afterward.

Using the Self-propel Drive

Self-propel Model only

The lawn mower has three ground speeds. **1** is slow, **2** is medium, and **3** is fast. The ground speed control is located at the rear of the belt cover (Fig. 9).

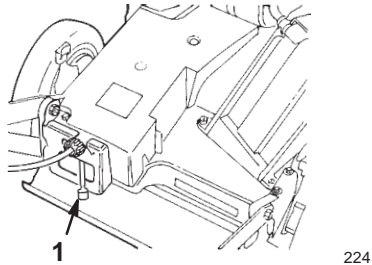

Figure 9

1. Ground speed control

1. Move the ground speed control to the **N** (Neutral) position.
2. Start the engine.
3. Squeeze the control bar against the handle to the **Run/Drive** position (Fig. 10).

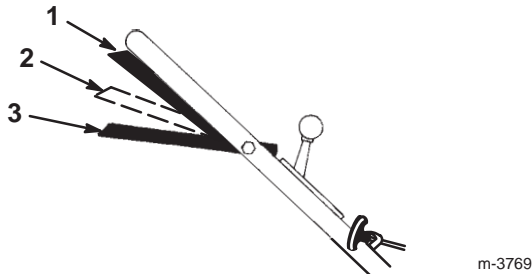

Figure 10

1. Run/Drive position
2. Run/Shift position
3. Stop position

Note: Do not shift speeds while squeezing the control bar against the handle in the **Run/Drive** position; this can damage the transmission. Move the control bar to the **Run/Shift** position (Fig. 10) when you change the ground speed.

Note: You can vary the ground speed by increasing or decreasing the distance between the control bar and the handle. Lower the control bar to decrease the ground speed when you are making a turn or if the lawn mower is moving too fast for you. If you lower the control bar too far, the lawn mower stops self-propelling. Squeeze the control bar closer to the handle to increase the ground speed. When you hold the control bar tight against the handle, the lawn mower self-propels at the maximum

ground speed. Move the ground speed control to the **Neutral** position when you use the lawn mower for trimming or whenever you leave the lawn mower.

Using the Discharge Tunnel Plug

1. Stop the engine and wait for all moving parts to stop.
2. Insert the discharge tunnel plug; refer to Installing the Discharge Tunnel Plug on page 6.
3. To remove the plug, move the discharge door handle rearward and lift up the spring clip on the bottom of the plug. When the plug is unlocked, pull it out of the discharge tunnel.

Note: When grass is thick and lush, clippings may collect on and around the discharge tunnel plug. This may make removing the plug difficult. Clean the plug thoroughly after each use.

Adjusting the Cutting Height

Each wheel is adjusted individually with a wheel height adjustment lever. Cutting heights are 3/4 inch (1.9 cm), 1-1/4 inches (3.2 cm), 1-3/4 inches (4.4 cm), 2-1/4 inches (5.7 cm), 2-3/4 inches (7.0 cm), and 3-1/4 inches (8.3 cm).

Danger

Adjusting the cutting height levers could bring your hands into contact with a moving blade and result in serious injury.

- Stop the engine and wait for all moving parts to stop before adjusting the cutting height.
- Do not put your fingers under the housing when adjusting the cutting height.

1. Pull the wheel height adjustment lever toward the wheel (Fig. 11) and move it to the desired setting.

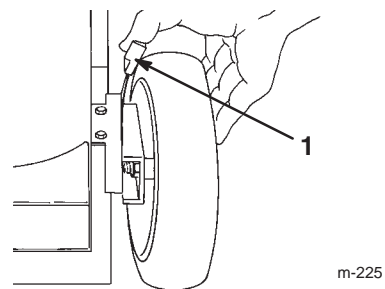

Figure 11

1. Wheel height adjustment lever

2. Release the wheel height adjustment lever and seat it securely in the notch.
3. Adjust all the wheels to the same cutting height setting.

Using the Grass Bag

Occasionally, you may want to use the grass bag for bagging extra long grass, lush grass, or leaves.

Installing the Grass Bag

1. Stop the engine and wait for all moving parts to stop.
2. Ensure that the discharge door handle is fully forward and that the pin is engaged in the catch (Fig. 12).

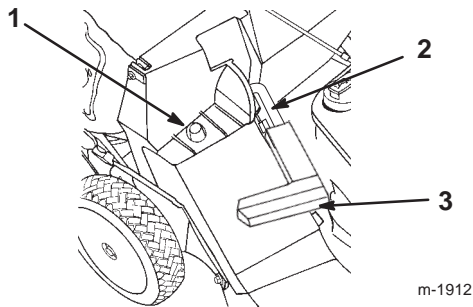

Figure 12

1. Bag frame on retaining post
2. Pin engaged in catch
3. Handle fully forward and discharge door closed

3. Slide the hole in the bag frame onto the retaining post on the discharge tunnel (Fig. 12).
4. Set the rear of the bag frame onto the bag support rod.
5. Pull the discharge door handle forward until the pin clears the catch, and move the handle rearward until the pin locks in the bag notch (Fig. 13).

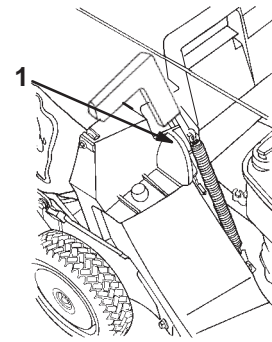

Figure 13

1. Pin locked in bag notch

Note: The discharge door in the lawn mower housing is now open.

Mowing with the Grass Bag



Warning



A worn grass bag could allow small stones and other similar debris to be thrown in the operator's or bystander's direction and result in serious personal injury or death to the operator or bystanders.

Check the grass bag frequently. If it is damaged, install a new Exmark replacement bag.

Cut the grass until the bag is full.

Important Do not overfill the bag.

Removing the Grass Bag

1. Stop the engine and wait for all moving parts to stop.
2. Raise the discharge door handle and move it forward to engage the pin with the catch (Fig. 12).
3. Grasp the handles at the front and the rear of the bag and lift the bag off the lawn mower.
4. Gradually tip the bag forward to empty the clippings.
5. To install the bag, refer to Installing the Grass Bag on page 11.



Danger



If the discharge door does not close completely, the lawn mower could throw objects, causing serious personal injury or death.

If you cannot close the door because the grass clippings clog the discharge area, stop the engine and gently move the discharge door handle back and forth until you can close the door completely. If you still cannot close the door, remove the obstruction with a stick, not your hand.



Danger



The lawn mower can throw grass clippings and other objects through an open discharge tunnel. Objects thrown with enough force could cause serious personal injury or death to the operator or bystander.

Never open the door on the discharge tunnel when the engine is running.

Operating Tips

- Review the safety instructions and read this manual carefully before operating the lawn mower.
- Clear the area of sticks, stones, wire, branches, and other debris that the blade could hit and throw.
- Keep everyone, especially children and pets, away from the area of operation.
- Avoid striking trees, walls, curbs, or other solid objects. Never deliberately mow over any object.
- If the lawn mower strikes an object or starts to vibrate, immediately stop the engine, disconnect the wire from the spark plug, and examine the lawn mower for damage.
- Maintain a **sharp blade** throughout the cutting season. Periodically file down nicks on the blade.
- Replace the blade when necessary with an original Exmark replacement blade.
- Mow only dry grass or leaves. Wet grass and leaves tend to clump on the yard and can cause the lawn mower to plug or the engine to stall.



Warning



Wet grass or leaves can cause serious injury if you slip and contact the blade.

Mow only in dry conditions.

- Clean the underside of the lawn mower housing after each mowing. See Cleaning under the Housing on page 15.
- Keep the engine in good running condition.
- Set the engine speed to the fastest position for the best cutting results.



Warning



Operating a lawn mower with its engine running at a speed greater than the factory setting can cause the lawn mower to throw a part of the blade or engine into the operator's or bystander's area and result in serious personal injury or death.

- **Do not change the engine speed setting.**
- **If you suspect the engine speed is faster than normal, contact an Authorized Service Dealer.**

- Clean the air filter frequently. Mulching stirs up more clippings and dust which clogs the air filter and reduces engine performance.

Cutting Grass

- Grass grows at different rates at different times of the year. In the summer heat, it is best to cut grass at the 2-1/4-inch (5.7 cm), 2-3/4-inch (7.0 cm), or 3-1/4-inch (8.3 cm) cutting height settings. Cut only about a third of the grass blade at a time. Do not cut below the 2-1/4-inch (5.7 cm) setting unless the grass is sparse or it is late fall when grass growth begins to slow down.
- When cutting grass over six inches (15 cm) tall, first mow at the highest cutting height setting and walk slower; then mow again at a lower setting for the best lawn appearance. If the grass is too long and the leaves clump on top of the lawn, the lawn mower may plug and cause the engine to stall.
- Alternate the mowing direction. This helps disperse the clippings over the lawn for even fertilization.

If the finished lawn appearance is unsatisfactory, try one or more of the following:

- Sharpen the blade.
- Walk at a slower pace while mowing.
- Raise the cutting height on your lawn mower.

- Cut the grass more frequently.
- Overlap cutting swaths instead of cutting a full swath with each pass.
- Set the cutting height on the front wheels one notch lower than the rear wheels. For example, set the front wheels at 2-1/4 inches (5.7 cm) and the rear wheels at 2-3/4 inches (7.0 cm).

Cutting Leaves

- After cutting the lawn, ensure that half of the lawn shows through the cut leaf cover. You may need to make more than one pass over the leaves.
- For light leaf coverage, set all the wheels at the same cutting height setting.
- If there are more than five inches (12.7 cm) of leaves on the lawn, set the front cutting height one or two notches higher than the rear cutting height. This makes it easier to feed the leaves under the lawn mower housing.
- Slow down your mowing speed if the lawn mower does not cut the leaves finely enough.
- If you mow over oak leaves, you can add lime to the grass in the spring to reduce the acidity of the oak leaves.

Maintenance

Note: Determine the left and right sides of the machine from the normal operating position.

Recommended Maintenance Schedule

Maintenance Service Interval	Maintenance Procedure
Each Use	<ul style="list-style-type: none"> • Check the engine oil level. Refer to Checking the Engine Oil Level on page 15. • Check the stopping time of the blade brake. The blade must stop within 3 seconds of releasing the control bar; if it does not, contact an Authorized Service Dealer for repair. • Remove grass clippings and dirt from under the housing. Refer to Cleaning under the Housing on page 15. • Clean the discharge tunnel and the discharge tunnel plug. Refer to Cleaning the Discharge Tunnel and Plug on page 16. • Inspect the air cleaner elements. Refer to Servicing the Air Cleaner on page 16.
5 Hours	<ul style="list-style-type: none"> • Check the blade and the engine mounting fasteners. Tighten loose fasteners.
25 Hours	<ul style="list-style-type: none"> • Clean the air cleaner elements; clean them more frequently in dusty operating conditions. Refer to Servicing the Air Cleaner on page 16. • Lubricate the pivot arms (self-propel model only). Refer to Lubricating the Pivot Arms on page 19.
50 Hours	<ul style="list-style-type: none"> • Change the engine oil.¹ Refer to Changing the Engine Oil on page 19. • Sharpen or replace the blade; maintain it more frequently if the edge dulls quickly in rough or in sandy conditions. Refer to Maintaining the Blade on page 17. • Remove grass clippings and debris from under the belt cover. Refer to Cleaning under the Belt Cover on page 18. • Have an authorized engine servicing dealer check and adjust the flywheel brake pad.
75 Hours	<ul style="list-style-type: none"> • Adjust the self-propel drive system (self-propel model only). Refer to Adjusting the Self-propel Drive on page 19.
100 Hours	<ul style="list-style-type: none"> • Inspect, clean, and adjust the spark plug; replace it if necessary. Refer to Servicing the Spark Plug on page 20. • Lubricate the gear case (self-propel model only). Refer to Lubricating the Gear Case on page 20. • Adjust the blade brake cable. Refer to Adjusting the Blade Brake Cable on page 20. • Service the wheels. Refer to Servicing the Wheels on page 21. • Have an authorized engine servicing dealer check and adjust the idle speed, check and adjust the valve clearance, and clean the fuel tank and filter.
250 Hours	<ul style="list-style-type: none"> • Replace the air cleaner elements; replace them more frequently in dusty operating conditions. Refer to Servicing the Air Cleaner on page 16. • Replace the spark plug. Refer to Servicing the Spark Plug on page 20. • Have an authorized engine servicing dealer check for leaks in the fuel system and/or a deteriorating fuel hose. Replace parts if necessary.

¹Change the engine oil after the first 5 operating hours.

Important Refer to your engine owner's manual for additional maintenance procedures.



Caution



If you leave the wire on the spark plug, someone could accidentally start the engine and seriously injure you or other bystanders.

Disconnect the wire from the spark plug before you do any maintenance. Set the wire aside so that it does not accidentally contact the spark plug.

Checking the Engine Oil Level

Before you use the lawn mower, ensure that the oil level is between the lower limit and the upper limit marks as shown on the dipstick (Fig. 5). If the oil level is below the lower limit mark, add oil. Refer to Filling the Crankcase with Oil on page 7.

Cleaning under the Housing

To ensure the best performance, keep the underside of the housing clean (Fig. 14).

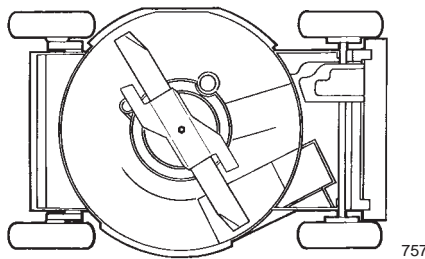

Figure 14

Washing Method

1. Position the lawn mower on a flat concrete or asphalt surface near a garden hose.
2. Start the engine.
3. Hold the running water at handle level and direct the water to flow on the ground just in front of the **right rear** tire (Fig. 15).

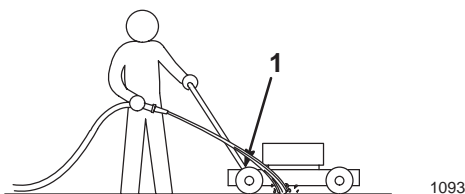

Figure 15

1. Rear right tire

Note: The water will splash into the blade and clean out the clippings. Let the water run until you no longer see clippings being washed out from under the housing.

4. Stop the engine and wait for all moving parts to stop.
5. Turn off the water.
6. Start the lawn mower again and let it run for a few minutes to dry out the lawn mower and its components.

Scraping Method

If the washing method does not remove all the debris from under the lawn mower, scrape it clean.

1. Disconnect the wire from the spark plug (Fig. 6).
2. Drain the fuel from the fuel tank.



Warning



Tipping the lawn mower may cause the fuel to leak from the carburetor or the fuel tank. Gasoline is extremely flammable, highly explosive, and, under certain conditions, can cause personal injury or property damage.

Avoid fuel spills by running the engine dry or by removing the gasoline with a hand pump; never siphon.

3. Tip the lawn mower onto its **left** side (air cleaner up) (Fig. 14).
4. Remove the dirt and grass clippings with a hardwood scraper. Avoid burrs and sharp edges.
5. Return the lawn mower to the operating position.
6. Fill the fuel tank with fresh gasoline.
7. Connect the wire to the spark plug.

Cleaning the Discharge Tunnel and Plug

Remove the plug from the discharge tunnel and clean it after each use.

Always ensure that the discharge tunnel door closes securely when you release the handle. If the debris prevents the discharge door from closing securely, clean the inside of the discharge tunnel and the door thoroughly.

! **Warning** !

Grass clippings and other objects can be thrown from an open discharge tunnel and cause serious injury or kill the operator or bystanders.

Never start or operate the lawn mower unless *one* of the following is true:

- **The discharge tunnel plug is locked securely in the discharge tunnel.**
- **The grass bag is locked in place.**
- **The optional side discharge chute is locked in place.**
- **The discharge tunnel door is locked in place.**

Servicing the Air Cleaner

Inspect the air cleaner elements after every time you use the lawn mower.

Clean the cover, base, and foam and paper elements after every 25 operating hours. Replace the elements after every 250 operating hours or sooner if they are damaged or excessively dirty.

Important Do not operate the engine without the air cleaner assembly; extreme engine damage will occur.

1. Stop the engine and wait for all moving parts to stop.
2. Disconnect the wire from the spark plug (Fig. 6).
3. Remove the 2 wing bolts that secure the cover (Fig. 16).

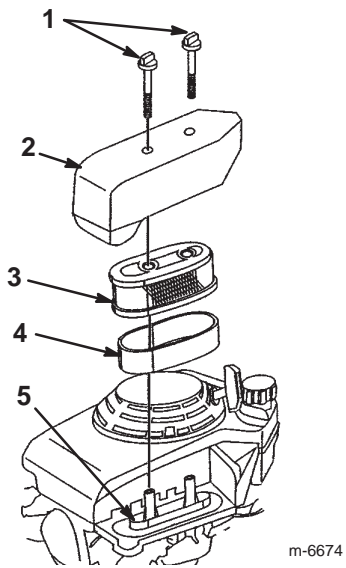

Figure 16

- | | |
|------------------|-----------------|
| 1. Wing bolts | 4. Foam element |
| 2. Cover | 5. Base |
| 3. Paper element | |

4. Remove the cover.

Note: Be careful to prevent dirt and debris from falling into the base.

5. Remove the foam and paper elements from the base (Fig. 16).
 6. Remove the foam element from the paper element (Fig. 16).
 7. Inspect the foam and paper elements, and replace them if they are damaged or excessively dirty.
 8. Tap the paper element on a hard surface several times or use compressed air not exceeding 30 psi (207 kPa) through the filter from the wire screen side to remove any excess dirt. If the paper element is excessively dirty, replace it.
- Note:** Never try to brush dirt off the paper element; brushing forces the dirt into the fibers.
9. Clean the foam element in warm, soapy water or in a **nonflammable** solvent.
- Note:** Do not use gasoline to clean the foam element because it could create a risk of fire or explosion.- 10. Rinse and dry the foam element thoroughly.
- 11. Dip the foam element in clean engine oil, then squeeze out the excess oil.

Note: Excess oil in the foam element restricts the air flow through the element and may reach the paper filter and clog it.

12. Wipe dirt from the base and the cover with a moist rag.

Note: Be careful to prevent dirt and debris from entering the air duct leading to the carburetor.

13. Install the air cleaner elements and ensure that they are properly positioned.

14. Securely install the cover with the 2 wing bolts.

Maintaining the Blade

Always mow with a sharp blade. A sharp blade cuts cleanly and without tearing or shredding the grass blades.

1. Stop the engine and wait for all moving parts to stop.
2. Disconnect the wire from the spark plug (Fig. 6).
3. Drain the gasoline from the fuel tank.
4. Tip the lawn mower onto its **right** side (air cleaner up) (Fig. 17).

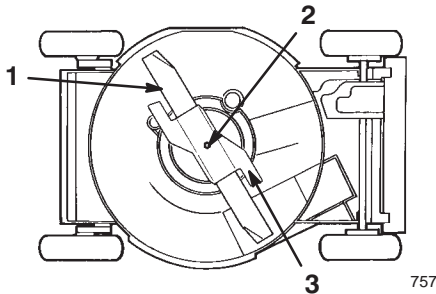
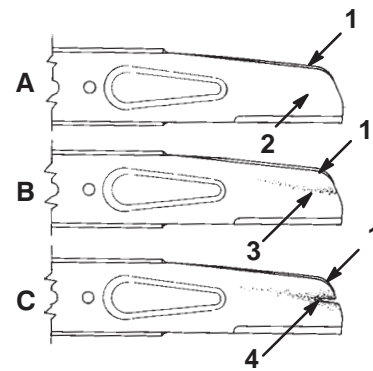

Figure 17

1. Blade
2. Bolt and lock washer
3. Accelerator

Inspecting the Blade

Carefully examine the blade for sharpness and wear, especially where the flat and the curved parts meet (Fig. 18A). Because sand and abrasive material can wear away the metal that connects the flat and curved parts of the blade, check the blade before using the lawn mower. If you notice a slot or wear (Figs. 18B and 18C), replace the blade; refer to Removing the Blade on page 17.



270

Figure 18

1. Sail
2. Flat part of blade
3. Wear
4. Slot formed

Note: For the best performance, install a new blade before the cutting season begins. During the year, file down any small nicks to maintain the cutting edge.

Danger

A worn or damaged blade can break, and a piece of the blade could be thrown into the operator's or bystander's area, resulting in serious personal injury or death.

- Inspect the blade periodically for wear or damage.
- Replace a worn or damaged blade.

Removing the Blade

1. Grasp the end of the blade using a rag or a thickly padded glove.
2. Remove the blade bolt, the lockwasher, the accelerator, and the blade (Fig. 17).

Sharpening the Blade

File the top side of the blade to maintain its original cutting angle (Fig. 19A) and inner cutting edge radius (Fig. 19B). The blade will remain balanced if you remove the same amount of material from both cutting edges.

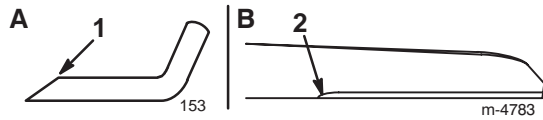

Figure 19

1. Sharpen at this angle only
2. Maintain the original radius here

Balancing the Blade

1. Check the balance of the blade by placing the center hole of the blade over a nail or screwdriver shank clamped horizontally in a vise (Fig. 20).

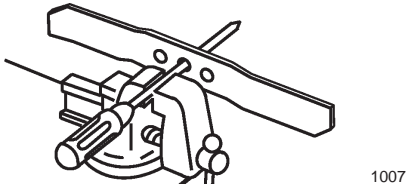

Figure 20

Note: You can also check the balance using a commercially manufactured blade balancer.

2. If either end of the blade rotates downward, file that end (not the cutting edge or the end near the cutting edge). The blade is properly balanced when neither end drops.

Installing the Blade

1. Install a sharp, balanced Exmark blade, the accelerator, the lock washer, and the blade bolt. The sail of the blade must point toward the top of the lawn mower housing for proper installation. Torque the blade bolt to 50 ft-lb (68 N·m).



Warning



Operating the lawn mower without the accelerator in place can cause the blade to flex, bend, or break, resulting in serious injury or death to the operator or bystanders.

Do not operate the lawn mower without the accelerator.

2. Return the lawn mower to its upright position.
3. Connect the wire to the spark plug.

Cleaning under the Belt Cover

Self-propel Model only

Keep the area under the belt cover free of debris.

1. Stop the engine and wait for all moving parts to stop.
2. Disconnect the wire from the spark plug (Fig. 6).
3. Remove the bolts that secure the belt cover to the lawn mower housing (Fig. 21).

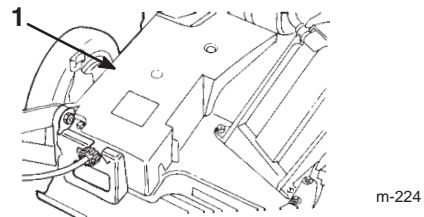

Figure 21

1. Belt cover
4. Lift off the cover and brush out all the debris around the belt area.
5. Install the belt cover.
6. Connect the wire to the spark plug.

Lubricating the Pivot Arms

Self-propel Model only

After every 25 operating hours or when the season ends, lubricate the pivot arms.

1. Move the rear wheel cutting height levers to the center setting.
2. Wipe the grease fittings with a clean rag (Fig. 22).

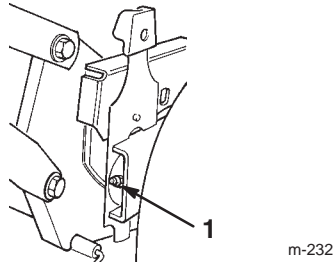

Figure 22

1. Grease fitting

3. Install a grease gun onto the fitting and gently apply two or three pumps of #2 multi-purpose lithium base grease (Fig. 22).

Note: Applying grease with excessive pressure may damage the seals.

Adjusting the Self-propel Drive

Self-propel Model only

If the lawn mower does not self-propel or has a tendency to creep forward when the control bar is **more** than 1-1/2 inches (3.8 cm) from the handle, adjust the wheel drive control knob on the rear of the gear box (Fig. 23).

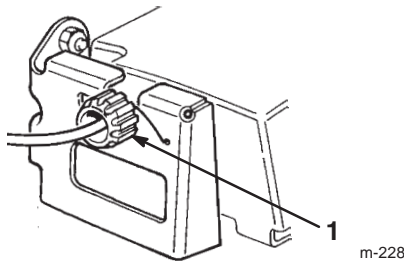

Figure 23

1. Control knob

1. Close the door in the lawn mower housing and remove the grass bag.
2. Rotate the control knob clockwise 1/2 turn if the lawn mower does not self-propel. If the lawn mower creeps forward, rotate the knob 1/2 turn counterclockwise (Fig. 23).

3. Slowly pull the lawn mower rearward while you gradually move the control bar toward the handle.

Note: The adjustment is correct when the rear wheels stop turning and the control bar is about one inch (2.5 cm) from the handle (Fig. 24).

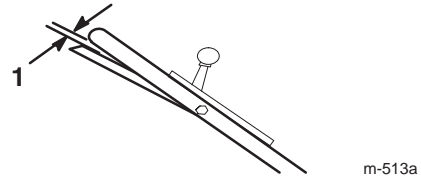

Figure 24



1. One inch (2.5 cm)

Changing the Engine Oil

Change the oil after the first 5 operating hours (or the first month); and then after every 50 operating hours (or every 6 months).

1. Run the engine to warm the engine oil.

Note: Warm oil flows better and carries more contaminants.

	Warning	
<p>Oil may be hot after engine has been run, and contact with hot oil can cause severe personal injury.</p> <p>Avoid contacting the hot engine oil when you drain it.</p>		

2. Stop the engine and wait for all moving parts to stop.
3. Disconnect the wire from the spark plug (Fig. 6).
4. Place a suitable drain pan under the dipstick/oil drain (Fig. 6).
5. Clean around the dipstick.
6. Remove the dipstick by rotating the cap counterclockwise and pulling it out.
7. Raise the **left** side of the lawn mower to drain the oil from the dipstick fill tube into the drain pan.
8. After draining the oil, return the lawn mower to the operating position.
9. Fill the crankcase with fresh oil to the upper limit mark on the dipstick. Refer to the Filling the Crankcase with Oil on page 7.
10. Insert the dipstick into the filler neck and rotate the cap clockwise until it is tight.

11. Wipe up any spilled oil.
12. Connect the wire to the spark plug.
13. Recycle the used oil according to local codes.

Servicing the Spark Plug

Check the spark plug after every 100 operating hours or yearly; replace it after every 250 operating hours or every 2 years. Use an NGK® BPR5ES or Nippondenso® W16EPR-U spark plug or equivalent.

1. Stop the engine and wait for all moving parts to stop.
2. Disconnect the wire from the spark plug (Fig. 6).
3. Clean around the spark plug.
4. Remove the spark plug from the cylinder head.

Important Replace a cracked, fouled, or dirty spark plug. Do not clean the electrodes because grit entering the cylinder can damage the engine.

5. Set the gap on the plug to 0.030 in. (0.76 mm) (Fig. 25).

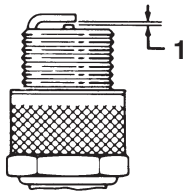

m-110

Figure 25

1. 0.030 in. (0.76 mm)
-
6. Carefully install the spark plug by hand (to avoid cross threading) until it is hand tight.
 7. Tighten the spark plug an additional 1/2 turn if it is new; otherwise, tighten it an additional 1/8 to 1/4 turn.

Important A loose spark plug can become very hot and can damage the engine; overtightening a spark plug may damage the threads in the cylinder head.

8. Connect the wire to the spark plug.

Lubricating the Gear Case

Self-propel Model only

After every 100 operating hours, grease the gear case.

1. Remove the grass bag.
2. Install a grease gun onto the fitting through the belt cover opening (Fig. 26).

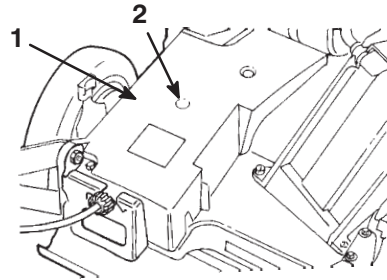

m-224

Figure 26

1. Belt cover
 2. Grease fitting
-
3. Gently apply one to two pumps of #2 multi-purpose lithium-base grease.
 4. Install the grass bag.

Adjusting the Blade Brake Cable

Whenever you install a new blade brake cable assembly, adjust it.

1. Stop the engine and wait for all moving parts to stop.
2. Disconnect the wire from the spark plug (Fig. 6).
3. Check the adjustment of the cable by moving the control bar toward the handle until you remove the slack in the cable. The gap between the brake lever and the handle must be between 3/16 and 1/4 in. (5 and 6 mm). To adjust the cable, go to step 4.

4. To adjust the cable, do the following:

Hand-push Model

A. Loosen the jam nut on the blade brake cable (Fig. 27).

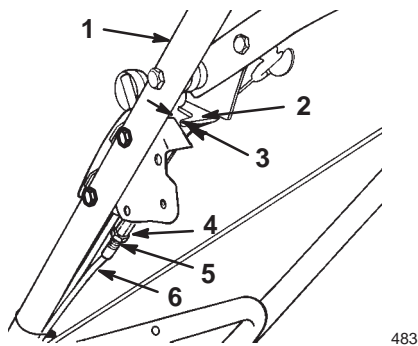

Figure 27

- | | |
|--------------------------------|-------------------|
| 1. Handle | 4. Cable adjuster |
| 2. Brake lever | 5. Jam nut |
| 3. 3/16 to 1/4 in. (5 to 6 mm) | 6. cable conduit |

B. Insert a 3/16 to 1/4 in. (5 to 6 mm) object between the brake lever and the handle.

C. Turn the cable adjuster on the brake cable until you remove the slack.

D. Tighten the jam nut.

Self-propel Model

A. Loosen the nut on the cable bracket (Fig. 28).

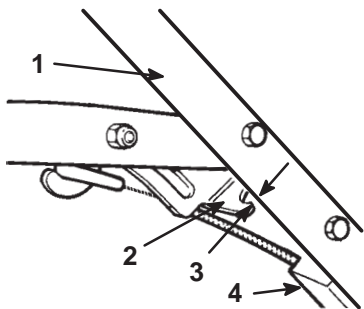

Figure 28

- | | |
|----------------|--------------------------------|
| 1. Handle | 3. 3/16 to 1/4 in. (5 to 6 mm) |
| 2. Brake lever | 4. cable bracket |

B. Insert a 3/16 to 1/4 in. (5 to 6 mm) object between the brake lever and the handle.

C. Pull down on the cable conduit until you remove the slack from the wire.

D. Tighten the nut.

Servicing the Wheels

Removing the Wheels

1. Stop the engine and wait for all moving parts to stop.
2. Disconnect the wire from the spark plug (Fig. 6).
3. Remove the bolt, the wheel spacer, and the locknut mounting the wheel to the pivot arm (Fig. 29).

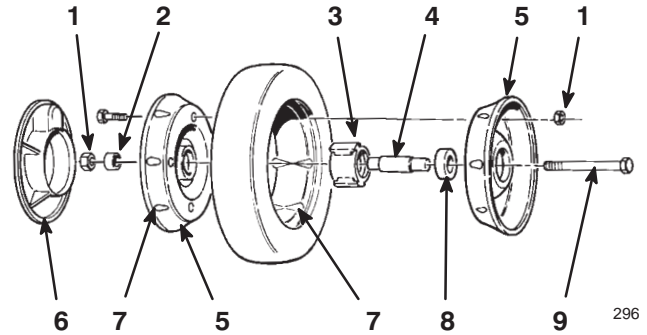

Figure 29

- | | |
|-------------------------|-------------------------------------|
| 1. Locknut | 6. Plastic cover (rear wheels only) |
| 2. Wheel spacer | 7. Lug |
| 3. Bearing/hub assembly | 8. Bearing (2) |
| 4. Bearing spacer | 9. Bolt |
| 5. Wheel half | |

4. Separate the wheel halves from the tire by removing four bolts and four locknuts (Fig. 29).

Note: If you remove the bearings from the bearing/hub assembly, remove them by pressing on the bearing spacer (Fig. 29).

Assembling the Wheels

1. Position the tire onto one wheel half, aligning the lugs on each (Fig. 29).
2. Place the bearing/hub assembly into the center hole of the wheel half. Ensure that the legs of the hub are positioned over the flange of the hole (Fig. 29).
3. Place the other wheel half onto the bearing/hub assembly, aligning the wheel and the tire lugs and the mounting holes (Fig. 29).
4. Using two 1/4–20 x 1.50 in. (6 x 38 mm) fully threaded bolts and non-locking nuts, loosely secure the wheel halves together. Mount the bolts in the opposing holes (Fig. 29).
5. Check the alignment of all parts and tighten the bolts, alternating from side to side for a uniform fit, until the wheel halves are drawn together (Fig. 29).



6. Install the two bolts and two locknuts previously removed in the remaining holes in the wheel halves and tighten. Remove the two long bolts and replace them with two bolts and two locknuts (Fig. 29).
7. Install the wheel to the pivot arm with the bolts, a spacer, and a locknut. Ensure that the spacer is positioned between the wheel hub and the pivot arm (Fig. 29).

Storage

To prepare the lawn mower for off-season storage, perform the recommended maintenance procedures. Refer to Maintenance on page 14.

Store the lawn mower in a cool, clean, and dry place. Cover the lawn mower to keep it clean and protected.

Preparing the Fuel System

Warning

Gasoline can vaporize if you store it over long periods of time and explode if it comes into contact with an open flame.

- **Do not store gasoline over long periods of time.**
- **Do not store the lawn mower with gasoline in the fuel tank or the carburetor in an enclosure with an open flame. (For example, a furnace or a water heater pilot light.)**
- **Allow the engine to cool before storing it in any enclosure.**

Empty the fuel tank when mowing the last time before storing the lawn mower.

1. Run the lawn mower until the engine stops from running out of fuel.
2. Prime the engine and start it again.
3. Allow the engine to run until it stops. When you can no longer start the engine, it is sufficiently dry.

Preparing the Engine

1. While the engine is still warm, change the oil from the crankcase. Refer to Changing the Engine Oil on page 19.
2. Remove the spark plug (Fig. 6).
3. Using an oil can, add about one tablespoon of oil to the crankcase through the spark plug hole.
4. Slowly rotate the engine several times, using the starter rope, to distribute the oil.

5. Install the spark plug but **do not** connect the wire to the spark plug.

General Information

1. Clean the lawn mower housing. Refer to Cleaning under the Housing on page 15.
2. Clean any dirt and chaff from the cylinder, cylinder head fins, and blower housing.
3. Remove grass clippings, dirt, and grime from the external parts of the engine, the shrouding, and the top of the lawn mower housing.
4. Check the condition of the blade. Refer to Maintaining the Blade on page 17.
5. Service the air cleaner; refer to Servicing the Air Cleaner on page 16.
6. Lubricate the pivot arms (self-propel model only); refer to Lubricating the Pivot Arms on page 19.
7. Tighten all nuts, bolts, and screws.
8. Touch up all rusted or chipped paint surfaces with paint available from an Authorized Service Dealer.

Removing the Lawn Mower from Storage

1. Check and tighten all fasteners.
2. Remove the spark plug and spin the engine rapidly using the starter to blow the excess oil from the cylinder.
3. Clean the spark plug or replace it if it is cracked, broken, or if the electrodes are worn.
4. Install the spark plug. Refer to Servicing the Spark Plug on page 20.
5. Perform any needed maintenance procedures; refer to Maintenance on page 14.
6. Fill the fuel in the fuel tank with fresh gasoline.
7. Check the engine oil level.
8. Connect the wire to the spark plug.

Accessories

You may purchase the following accessory from an Authorized Service Dealer:

Side Discharge Kit

Troubleshooting

Exmark designed and built your lawn mower for trouble-free operation. Check the following components and items carefully, and refer to Maintenance on page 14 for more information. If a problem continues, contact an Authorized Service Dealer.

Problem	Possible Causes	Corrective Action
Engine does not start	<ol style="list-style-type: none"> 1. The fuel tank is empty or the fuel system contains stale fuel. 2. The throttle lever is not in the Choke position. 3. The wire is not connected to the spark plug. 4. The spark plug is pitted, fouled, or the gap is incorrect. 	<ol style="list-style-type: none"> 1. Drain and/or fill the fuel tank with fresh gasoline. If the problem persists, contact an Authorized Service Dealer. 2. Move the throttle lever to the Choke position. 3. Connect the wire to the spark plug. 4. Check the spark plug and adjust the gap if necessary. Replace the spark plug if it is pitted, fouled, or cracked.
Engine starts hard or loses power	<ol style="list-style-type: none"> 1. The fuel tank contains stale fuel. 2. The fuel cap vent hole is plugged. 3. The air cleaner elements are dirty and are restricting the air flow. 4. The underside of the lawn mower housing contains clippings and debris. 5. The spark plug is pitted, fouled, or the gap is incorrect. 6. The engine oil level is low or the oil is dirty. 	<ol style="list-style-type: none"> 1. Drain and fill the fuel tank with fresh gasoline. 2. Clean the fuel cap vent hole or replace the fuel cap. 3. Service the air cleaner elements. 4. Clean under the lawn mower housing. 5. Check the spark plug and adjust the gap if necessary. Replace the spark plug if it is pitted, fouled, or cracked. 6. Check the engine oil. Change the oil if it is dirty or add oil if it is low.
Engine runs rough	<ol style="list-style-type: none"> 1. The wire is not connected to the spark plug. 2. The spark plug is pitted, fouled, or the gap is incorrect. 3. The throttle lever is not in the Fast position. 4. The air cleaner elements are dirty and are restricting the air flow. 	<ol style="list-style-type: none"> 1. Connect the wire to the spark plug. 2. Check the spark plug and adjust the gap if necessary. Replace the spark plug if it is pitted, fouled, or cracked. 3. Move the throttle lever to the Fast position. 4. Service the air cleaner elements.

Problem	Possible Causes	Corrective Action
Lawn mower or engine vibrates excessively	<ol style="list-style-type: none"> 1. The blade is bent or is out of balance. 2. The blade mounting nuts are loose. 3. The underside of the lawn mower housing contains clippings and debris. 4. The engine mounting bolts are loose. 	<ol style="list-style-type: none"> 1. Balance the blade. If the blade is bent, replace it. 2. Tighten the blade mounting nuts. 3. Clean under the lawn mower housing. 4. Tighten the engine mounting bolts.
Uneven cutting pattern	<ol style="list-style-type: none"> 1. All four wheels are not at the same height. 2. The blade is dull. 3. You are mowing in the same pattern repeatedly. 4. The underside of the lawn mower housing contains clippings and debris. 	<ol style="list-style-type: none"> 1. Place all four wheels at the same height. 2. Sharpen and balance the blade. 3. Change the mowing pattern. 4. Clean under the lawn mower housing.
Discharge chute plugs	<ol style="list-style-type: none"> 1. The throttle lever is not in the Fast position. 2. The cutting height is too low. 3. You are mowing too fast. 4. The grass is wet. 5. The underside of the lawn mower housing contains clippings and debris. 	<ol style="list-style-type: none"> 1. Move the throttle lever to the Fast position. 2. Raise the cutting height. 3. Slow down. 4. Allow the grass to dry before mowing. 5. Clean under the lawn mower housing.
Lawn mower does not self-propel (Self-propel model only)	<ol style="list-style-type: none"> 1. The self-propel drive cable is out of adjustment or is damaged. 2. There is debris under the belt cover. 	<ol style="list-style-type: none"> 1. Adjust the self-propel drive cable. Replace the cable if necessary. 2. Clean the debris from under the belt cover.

Limited Warranty **Exmark® Commercial Turf Equipment**

Exmark Mfg. Co. Inc. and its affiliate, Exmark Warranty Company, pursuant to an agreement between them, jointly warrant on the terms and conditions herein, that we will repair, replace or adjust any part manufactured by Exmark and found by us (in the exercise of our reasonable discretion) to be defective in factory material or workmanship.

This warranty is limited to one year from the date of original retail purchase (90 days for rental use) for any Exmark mower that is used for commercial or any other income producing purpose. The blade spindle assemblies will be warranted for three years, one year parts and labor with an additional two years parts only, from date of original retail purchase against defects in materials or workmanship. The hydrostatic traction drive system, excluding hoses, will be warranted for two full years from date of original retail purchase against defects in materials or workmanship. We will extend the Peerless 5-speed transmission manufacturer's warranty from 90 days to one year. Belts and tires are warranted for 90 days against defects in materials or workmanship.

The engine warranty is covered by its respective engine manufacturer. Please refer to the engine manufacturer's warranty statement that is included in the literature packet. We are not authorized to handle warranty adjustments on engines. Engine warranties should be referred to the nearest authorized service outlet of the engine manufacturer.

This warranty extends only to the original retail purchaser of the equipment. This warranty may not be assigned or transferred without the prior express written consent of Exmark and Exmark Warranty Company. The warranty period commences upon the date of original retail purchase.

The Exmark turf equipment, including any defective part, must be returned to an authorized Exmark service dealer within the warranty period. The warranty shall extend to the expense of repair or replacement (as determined by us) of the defective part, including labor. The warranty shall not extend to the expense of delivering the mower to the dealer for warranty work nor the expense of returning it back to the owner after repair or replacement. Our responsibility in respect to claims is limited to making the required repairs or replacements, and no claim of breach of warranty shall be cause for cancellation or rescission of the contract of sale of any Exmark mower. Proof of purchase may be required by the dealer to substantiate any warranty claim. All warranty work must be performed by an authorized Exmark service dealer.

This warranty extends only to turf equipment operated under normal conditions and properly serviced and maintained. The warranty expressly does not cover (1) any damage or deterioration due to normal use, wear and tear, or exposure; (2) normal maintenance services, such as oil change, cleaning, lubrication, or adjustment; (3) replacement of service items, such as oil, lubricants, spark plugs, or other items subject to normal service replacement; (4) damage or defects arising out of or relating to misuse, neglect, alteration, negligence, or accident; (5) repair or replacement arising from operation of or use of the turf equipment which is not in accordance with operating instructions as specified in the operator's manual or other operational instructions provided by Exmark; (6) repair or replacement arising as a result of any operation from turf equipment that has been altered or modified so as to, in the determination of Exmark or Exmark Warranty Company, adversely affect the operation, performance or durability of the equipment or that has altered, modified or affected the turf equipment so as to change the intended use of the product; (7) repair or replacement necessitated by use of parts, accessories or supplies, including gasoline, oil, or lubricants, incompatible with the turf equipment or other than as recommended in the operator's manual or other operational instructions provided by Exmark; (8) repairs or replacements resulting from parts or accessories which have adversely affected the operation, performance, or durability

of the turf equipment; or (9) damage or defects due to or arising out of repair of turf equipment by person or persons other than an authorized Exmark service dealer or the installation of parts other than genuine Exmark or Exmark recommended parts.

As a condition to this warranty, the customer shall have read the operator's manual and shall have completed and returned to Exmark Warranty Company, within the prescribed time, the Exmark warranty registration.

The sole liability of Exmark and Exmark Warranty Company, with respect to this warranty, shall be repair and replacement as set forth herein. Neither Exmark nor Exmark Warranty Company shall have liability for any other cost, loss, or damage, including but not limited to, any incidental or consequential loss or damage. In particular, we shall have no liability or responsibility for (1) expenses relating to gasoline, oil, or lubricants; (2) loss, cost, or expense relating to transportation or delivery of turf equipment from the location of owner or location where used by owner to or from any authorized Exmark service dealer; (3) travel time, overtime, after hours time, or other extraordinary repair charges or charge relating to repairs or replacements outside of normal business hours at the place of business of the authorized Exmark service dealer; (4) rental of like or similar replacement equipment during the period of any warranty, repair, or replacement work; (5) any telephone or telegram charges or travel charges; (6) loss or damage to person or property other than that covered by the terms of this warranty; (7) any claims for lost revenue, lost profit, or additional cost as a result of a claim of breach of warranty; or (8) attorney's fees.

There are no representations or warranties which have been authorized and provided to the buyer of the turf equipment other than as set forth in this warranty. Any and all statements or representations made by any seller of this equipment, including those set forth in any sales literature or made orally by any sales representative, are superseded by the terms of this warranty. Any affirmation of fact or promise made by Exmark, Exmark Warranty Company, or any of their representatives, to the buyer, which relates to the goods that are the subject of this warranty, shall be regarded as part of the basis of the bargain and shall not be deemed to create any express warranty that such goods shall conform to the affirmation or promise.

THERE ARE NO OTHER UNDERSTANDINGS, AGREEMENTS, REPRESENTATIONS, OR WARRANTIES, EXPRESS OR IMPLIED (INCLUDING BUT NOT LIMITED TO ANY REGARDING THE MERCHANTABILITY OR FITNESS FOR A PARTICULAR PURPOSE), NOT SPECIFIED HEREIN, RESPECTING THE EQUIPMENT WHICH IS THE SUBJECT OF THIS WARRANTY.

This warranty applies to all Exmark turf equipment sold in the United States and Canada and intended to be used for commercial purposes.

**SEE EXMARK'S COMPLETE
LINE OF PRODUCTS FOR TURF CARE**

LAZER Z[®]

LAZER Z[®] HP

LAZER Z[®] XP

LAZER Z[®] CT

TURF RANGER[®]

TURF TRACER[®]

TURF TRACER[®] HP

VIKING HYDRO

METRO[®]

METRO[®] HP



ULTRA VAC[™]

ULTRA VAC[™] QDS

GRASS CATCHER

SELF STEERING SULKY

MICRO-MULCH[™] ACCESSORY

 Warning 	
CALIFORNIA	
Proposition 65 Warning	
The engine exhaust from this product contains chemicals known to the State of California to cause cancer, birth defects, or other reproductive harm.	

©2003
EXMARK MFG. CO. INC.
INDUSTRIAL PARK BOX 808
BEATRICE, NE 68310
ALL RIGHTS RESERVED

FORM NO. 3327-672
(402) 223-6300
FAX (402) 223-5489
PRINTED IN U. S. A.

