

For Serial Nos.
320,000 & Higher

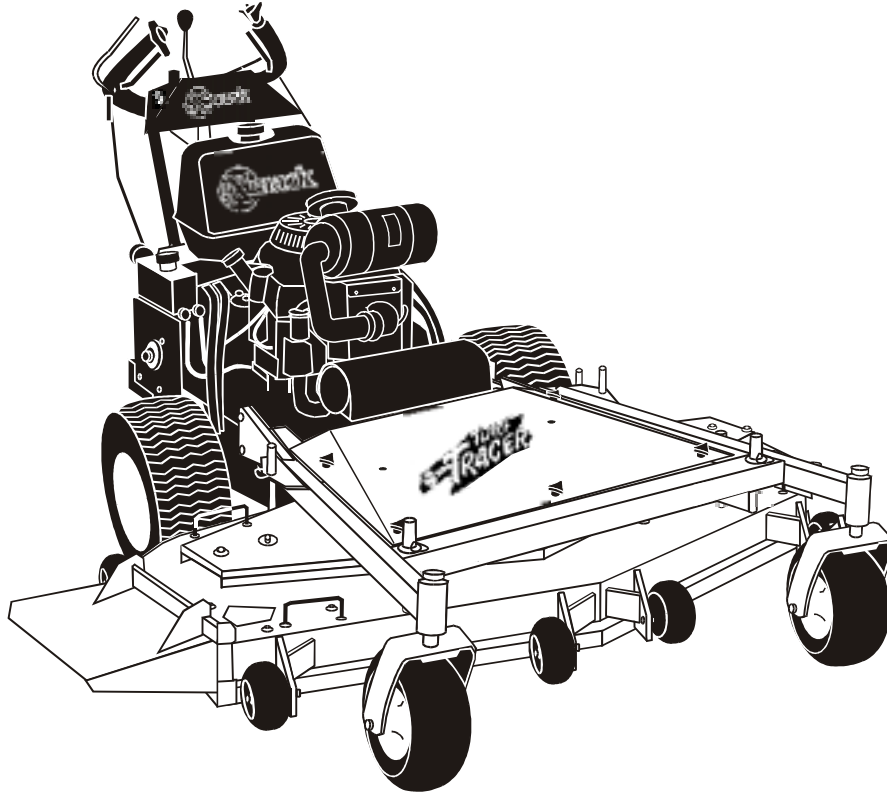

PARTS MANUAL

TURF TRACER®

CONGRATULATIONS on the purchase of your new Exmark mower. This product has been carefully designed and manufactured to give you a maximum amount of dependability and years of trouble-free operation.

If additional information is needed, or should you require trained mechanic service, contact your authorized Exmark equipment dealer or distributor.

If you need to order replacement parts from your dealer, always give the model number and serial number of your mower as well as the part number, description and quantity of the part needed.

The Serial No. plate of the tractor is located on top of the engine frame on the left hand side of the machine just inside the left wheel. The Serial No. plate for the mower deck is located on the rear right hand belt cover support under the front frame.

For ease of ordering and reference, we suggest that you record the information requested in the following identification table.

- Tractor Model No. _____
- Tractor Serial No. _____
- Deck Model No. _____
- Deck Serial No. _____
- Engine Model No. _____
- Engine Serial No. _____
- Date Purchased _____

Paste Labels From
Literature Packet Here

EXMARK PARTS PLUS® PROGRAM

EFFECTIVE DATE: September 1, 1995

Program

If your Exmark dealer does not have the Exmark part in stock, Exmark will get the parts to the dealer the next business day or the part will be FREE* Guaranteed!!

How the Program Works

1. If dealer does not have part in stock for a "down" unit at the time of request by customer, the dealer contacts his distributor by 1:00 p.m., local time, and requests Exmark Parts Plus® shipment of six (6) line items or less.
2. Distributor ships part(s) to dealer or customer, as requested by dealer, same day, overnight UPS. Distributor bills dealer for part and freight charges where applicable.
3. If distributor does not have the part(s) in stock to satisfy Exmark Parts Plus® order, he contacts Exmark by 3:00 p.m., central time, with an Exmark Parts Plus® order of six (6) line items or less.
4. If order is received by 3:00 p.m. central time, Exmark ships part(s) direct to dealer or customer, as requested by distributor, same day, overnight UPS. Exmark bills the distributor for parts and shipping charges, where applicable.
5. The customer pays for the part and freight if it is shipped under the Exmark Parts Plus® and if it arrives in accordance to the program.
6. Who pays for the part and freight if it fails to arrive overnight in accordance to the program?
 - A. Under any circumstance the customer does not pay.
 - B. If the part does not arrive overnight due to:
 1. The dealer not submitting the Exmark Parts Plus® order to his Exmark distributor by 1:00 p.m., the dealer pays for the part and freight.
 2. The Distributor being unable to ship the part the same day or not submitting the Exmark Parts Plus® order to Exmark by 3:00 p.m., central time, the Distributor pays for the part and freight.
 3. Exmark being unable to ship the part and the Exmark parts order is received by 3:00 p.m., central time, Exmark pays for the part and freight.
 4. If the part does not arrive overnight due to the shipper (UPS), the shipper pays for the freight and Exmark pays for the part.

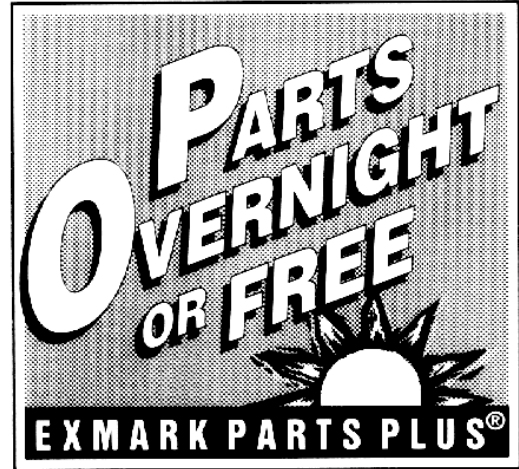

The following restrictions apply -- The Exmark Parts Plus® Program is available only through participating Exmark Dealers and applies only to orders submitted on this program Monday through Thursday. Parts Plus service is available only in the 48 contiguous United States. UPS has initiated a Saturday delivery program to many areas of the continental United States and can be requested for an overnight shipment on Friday to be delivered Saturday. The next day air charge, plus the Saturday delivery fee will be the responsibility of the purchaser. Exmark Mfg. will assume no responsibility for Saturday delivery shipments. To qualify, all Exmark Parts Plus® orders must be received by Exmark by 3:00 p.m., central time. Orders must be six (6) line items or less. Exclusions from the Exmark Parts Plus® Program are: Any wholegood or accessory in its entirety, engines and engine replacement parts, 5-speed Peerless transmissions and 5-speed transaxles, hydraulic or hydrostatic wheel motors, cutter decks and engine decks or any item exceeding United Parcel Service size and weight restrictions.

Due to UPS restrictions, aerosol spray paint is considered a hazardous material and cannot be shipped via UPS next day or Second Day Air.

Exmark Manufacturing stocks a limited supply of parts for transaxles, pumps and wheel motors. These parts can be ordered for Next Day Air shipment but will not be guaranteed per the Parts Plus Program.

WARNING

**READ OPERATOR'S MANUAL BEFORE
OPERATING OR SERVICING EXMARK EQUIPMENT.**

TABLE OF CONTENTS

<u>Description</u>	<u>Page</u>
Decals.....	12
Electrical Diagram.....	14
Electrical Group	13
Electrical Logic Schematic	15
Engine Deck Group.....	6 - 8
ECS Upper Handles & Controls	10-11
52" Mower Deck.....	2 - 3
Hydraulics Group	9
60" Mower Deck	4 - 5

52" MOWER DECK FMD524

Ref. No.	Part No.	Description	Qty. Req'd.	Ref. No.	Part No.	Description	Qty. Req'd.
1	103-1895	Support,deck 103-2324-01w/bsgs&decals	1	47	3234-11	Screw, whizlock 3/8-16 x 1	2
2	323-6	Capscrew, 3/8-16 x 1	2	48	3296-39	Nut, nylock 3/8-16.....	20
3	98-5975	Washer, disc spring 3/8	19	49	3256-4	Washer, 3/8.....	3
4	3290-357	Nut, whizlock 3/8-16	25	50	1-513034	Bearing, pivot.....	4
5	1-806009	Hairpin, .177.....	4	51	1-602604	Idler arm assy w/bearings.....	1
6	1-323539	Spacer.....	2		1-602591-03	Arm, deck idler	1
7	1-634619	Housing w/Brg,Spcr &Ring.....	3	52	1-603384	Bushing, idler pivot	2
8	1-413425	Spacer.....	2	53	1-602865	Idler arm, w/ brngs deck drive ..	1
9	1-513336	Bushing, deck support.....	2		1-602867-03	Arm, deck drive idler.....	1
10	32120-33	Ring, retaining (external).....	2	54	302-40	Zerk, 1/4-28 (90°)	2
11	1-373034	Washer, pivot	6	55	323-11	Capscrew, 3/8-16 x 2-1/4.....	2
12	1-543509	Bearing cone, tapered roller.....	4	56	1-413525	Link, rear deck support.....	2
	1-543508	Bearing cup, tapered roller.....	4	57	1-613204	Balljoint.....	2
13	103-1891-01	Fork, caster	2	58	1-603299	Roller, anti scalp.....	6
14	325-20	Capscrew, 1/2-13 x 6	2	59	98-5961	Capscrew, 3/8-16 x 4 Gr8.....	6
15	103-2355	Spacer, front caster.....	2	60	1-603602	Bushing, roller.....	6
16	103-1687	Tire & Wheel Asm	2	61	1-603620-01	Bracket, spring anchor	1
	1-513032	Tire, 11 x 4-5 4 ply.....	2	62	1-800805	Capscrew, 3/8-16 x 3 1/2 Gr8.....	2
	103-2274	Wheel.....	2	63	1-603414	Spring, extension.....	1
	1-633584	Bearing cup	4	64	1-602913-01	Baffle	1
17	103-2332	Cover, w/ decal.....	1	65▲	103-2328	Housing, cutter complete (center) ..	1
18	103-2318-01	Cover, deck.....	2		103-1140	Housing, cutter complete (outer)	2
19	103-2329	Belt, blade drive	1	66	3256-24	Washer, 3/8 SAE Flat	5
20	323-23	Capscrew, 3/8-16 x 4 1/2	1	67	1-603001	Rod, deck support	2
21	3219-6	Nut, 5/8-18 UNF	3	68	1-806332	Roll pin, 1/4 x 1-1/2.....	2
22	1-513208	Spring, disk	3	69	1-613098	Idler.....	1
23	1-633701	Sheave, blade drive	3	70	1-603805	Idler.....	1
24	1-513016	Bearing	6	71	1-513791	Bushing.....	1
25	1-323532	Housing, bearing.....	3	72	1-633988	Spacer	1
26	1-323528	Spacer, bearing.....	3	73	1-603050	Spacer	4
27	1-633573	Guard, dust	3	74	323-9	Capscrew, 3/8-16 x 1 3/4.....	2
28	32120-8	Snap ring.....	3	75❖	1-414521	Link Assy	2
29	10-8040	Key, square	4	76	1-323533	Spacer,Shv/Brg	3
30	103-2326	Spindle, outer blade (short).....	2	77	103-0865	Washer,Blade bolt hvy	3
31	103-2219	Spindle, center blade (long)	1	78	103-1331	Guard,bearing top.....	3
32	1-633482	Blade, notched air foil.....	3	79	103-0063	Seal, caster.....	4
	1-613251	Blade, solid air foil	3	80	3296-51	Nut, nyloc 3/4-10	2
	1-633485	Blade, low lift.....	3	81	1-543513	Cap, grease	2
■	1-633484	Blade, mulching.....	3	82	1-323385	Knob, 3 prong.....	5
	103-1578	Blade, bahia	3	83	1-323417	Washer, belt cover mounting....	5
33	3219-3	Nut, hex 3/8-24.....	2	84	1-811010	Plug	2
34	103-0862	Capscrew, 5/8-18x2 1/4 Gr8	3	85	1-543511	Seal, grease	2
35	323-8	Capscrew, 3/8-16 x 1 1/2	18	86	1-633581	Spacer, bearing	4
36	103-2335	Deck, 103-2321-01 w/ rods & baffle	1	87	1-633508	Washer, spring disk.....	6
37	103-2348-01	Chute, Discharge	1	88	1-633585	Bearing, cone	4
38	322-5	Capscrew, 5/16-18 x 1	2	89	1-800017	Bolt, Tap 5/16-18 x 3 1/4	2
39	3296-29	Nut, nylock 5/16-18	8	90	3296-45	Nut, nyloc 1/2-13 thin.....	2
40	322-2	Capscrew, 5/16-18 x 5/8	5	91	3256-3	Washer, 5/16 flat	6
41	1-303516	Pulley, V-Idler.....	2	92	323-12	Capscrew, 3/8-16 x 2 1/2	2
42	32128-20	Nut, whizlock 5/16-18.....	8	93	322-3	Capscrew, 5/16-18 x 3/4.....	1
43	1-603504	Spacer, tube.....	1	94	103-2495	Caster Wheel Assy.	2
44	1-603581	Sheave, mower drive.....	1	95	323-7	Capscrew, 3/8-16 x 1 1/4	8
45	1-603413	Spring, extension	1	96	103-2327	Complete Deck Assy	1
46	1-603497	Pulley, idler.....	1				

Exmark red touch up spray paint - P/N 1-850337

■ Requires installation of Micro-Mulch accessory for proper mulching. Mulch kit P/N MK524.

❖ Link assembly must be assembled to 6.89" (or approx. 6 7/8") length between center of ball joint & center of furthest hole.

See diagram on next page.

▲ Outer cutter housing complete includes sheave, washer & nut. Center cutter housing complete includes sheaves, washer, spacer & nut.

52" MOWER DECK FMD524

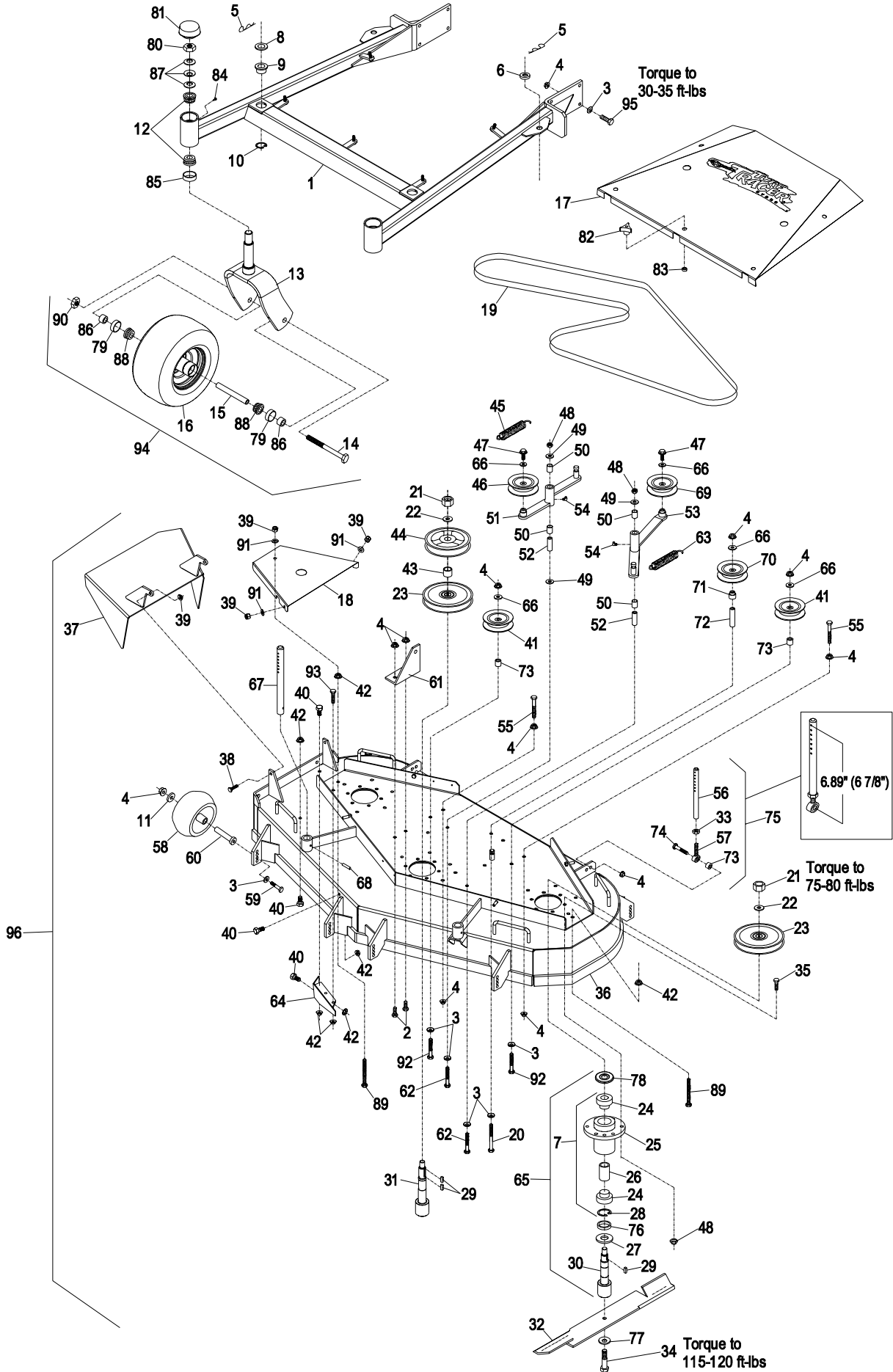

60" MOWER DECK FMD604

Ref. No.	Part No.	Description	Qty. Req'd.	Ref. No.	Part No.	Description	Qty. Req'd.
1	103-1896	Support, deck 103-2249-01 w/bsgs&decals1		46	1-603497	Pulley, idler.....	1
2	323-6	Capscrew, 3/8-16 x 1	2	47	3234-11	Screw, whizlock 3/8-16 x 1	2
3	98-5975	Washer, disc spring 3/8	19	48	3296-39	Nut, nylock 3/8-16	20
4	3290-357	Nut, whizlock 3/8-16.....	25	49	3256-4	Washer, 3/8.....	3
5	1-806009	Hairpin, .177	4	50	1-513034	Bearing, pivot	4
6	1-323539	Spacer	2	51	1-602604	Idler arm assy w/bearings	1
7	1-634619	Housing w/Brg, Spcr & Ring	3		1-602591-03	Arm, deck idler	1
8	1-413425	Spacer	2	52	1-603384	Bushing, idler pivot.....	2
9	1-513336	Bushing, deck support	2	53	1-602865	Idler arm, w/ brngs deck drive ..	1
10	32120-33	Ring, retaining (external).....	2		1-602867-03	Arm, deck drive idler	1
11	1-373034	Washer, pivot.....	6	54	302-40	Zerk, 1/4-28 (90°).....	2
12	1-543509	Bearing cone, tapered roller	4	55	323-11	Capscrew, 3/8-16 x 2-1/4	2
	1-543508	Bearing cup, tapered roller	4	56	1-413525	Link, rear deck support.....	2
13	103-1891-01	Fork, caster.....	2	57	1-613204	Balljoint.....	2
14	325-20	Capscrew, 1/2-13 x 6	2	58	1-603299	Roller, anti scalp.....	6
15	103-2355	Spacer, front caster	2	59	98-5961	Capscrew, 3/8-16 x 4 Gr8	6
16	103-1687	Tire & Wheel Asm.....	2	60	1-603602	Bushing, roller	6
	1-513032	Tire, 11 x 4-5 4 ply	2	61	1-603620-01	Bracket, spring anchor	1
	103-2274	Wheel	2	62	1-800805	Capscrew, 3/8-16 x 3 1/2 Gr8	2
	1-633584	Bearing cup.....	4	63	1-603414	Spring, extension	1
17	103-2275	Cover, w/ decal	1	64	1-602913-01	Baffle.....	1
18	103-2271-01	Cover, deck RH	1	65▲	103-2314	Housing, cutter complete (center) ..	1
	103-2272-01	Cover, deck LH.....	1		103-1140	Housing, cutter complete (outer)....	2
19	1-633173	Belt, blade drive	1	66	3256-24	Washer, 3/8 SAE Flat	5
20	323-23	Capscrew, 3/8-16 x 4 1/2	1	67	1-603001	Rod, deck support	2
21	3219-6	Nut, 5/8-18 UNF	3	68	1-806332	Roll pin, 1/4 x 1-1/2	2
22	1-513208	Spring, disk	3	69	1-613098	Idler	1
23	1-633701	Sheave, blade drive	3	70	1-603805	Idler	1
24	1-513016	Bearing	6	71	1-513791	Bushing	1
25	1-323532	Housing, bearing.....	3	72	1-633988	Spacer	1
26	1-323528	Spacer, bearing	3	73	1-603050	Spacer	4
27	1-633573	Guard, dust	3	74	323-9	Capscrew, 3/8-16 x 1 3/4	2
28	32120-8	Snap ring	3	75❖	1-414521	Link Assy.....	2
29	10-8040	Key, square.....	4	76	1-323533	Spacer, Shv/Brg	3
30	103-2326	Spindle, outer blade (short)	2	77	103-0865	Washer, Blade bolt hvy	3
31	103-2219	Spindle, center blade (long).....	1	78	103-1331	Guard, bearing top	3
32	1-633483	Blade, notched air foil	3	79	103-0063	Seal, caster	4
	1-613250	Blade, solid air foil.....	3	80	3296-51	Nut, nyloc 3/4-10	2
	1-613111	Blade, low lift.....	3	81	1-543513	Cap, grease.....	2
■	103-0301	Blade, mulching	3	82	1-323385	Knob, 3 prong.....	5
	103-1580	Blade, bahia	3	83	1-323417	Washer, belt cover mounting ...	5
33	3219-3	Nut, hex 3/8-24	2	84	1-811010	Plug	2
34	103-0862	Capscrew, 5/8-18x2 3/4 Gr8	3	85	1-543511	Seal, grease	2
35	323-8	Capscrew, 3/8-16 x 1 1/2	18	86	1-633581	Spacer, bearing.....	4
36	103-2278	Deck, 103-2267-01 w/ rods & baffle	1	87	1-633508	Washer, spring disk	6
37	103-2349-01	Chute, Discharge.....	1	88	1-633585	Bearing, cone.....	4
38	322-5	Capscrew, 5/16-18 x 1	2	89	1-800017	Bolt, Tap 5/16-18 x 3 1/4	2
39	3296-29	Nut, nylock 5/16-18.....	8	90	3296-45	Nut, nyloc 1/2-13 thin	2
40	322-2	Capscrew, 5/16-18 x 5/8	5	91	3256-3	Washer, 5/16 flat.....	6
41	1-303516	Pulley, V-Idler	2	92	323-12	Capscrew, 3/8-16 x 2 1/2	2
42	32128-20	Nut, whizlock 5/16-18.....	8	93	322-3	Capscrew, 5/16-18 x 3/4	1
43	1-603504	Spacer, tube	1	94	103-2495	Caster Wheel Assy.	2
44	103-2270	Sheave, mower drive	1	95	323-7	Capscrew, 3/8-16 x 1 1/4	8
45	1-603413	Spring, extension	1	96	103-2279	Complete Deck Assy.	1

Exmark red touch up spray paint - P/N 1-850337

■ Requires installation of Micro-Mulch accessory for proper mulching. Mulch kit P/N MK604.

❖ Link assembly must be assembled to 6.89" (or approx. 6 7/8") length between center of ball joint & center of furthest hole.

See diagram on next page.

▲ **Outer** cutter housing complete includes sheave, washer & nut. **Center** cutter housing complete includes sheaves, washer, spacer & nut.

60" MOWER DECK FMD604

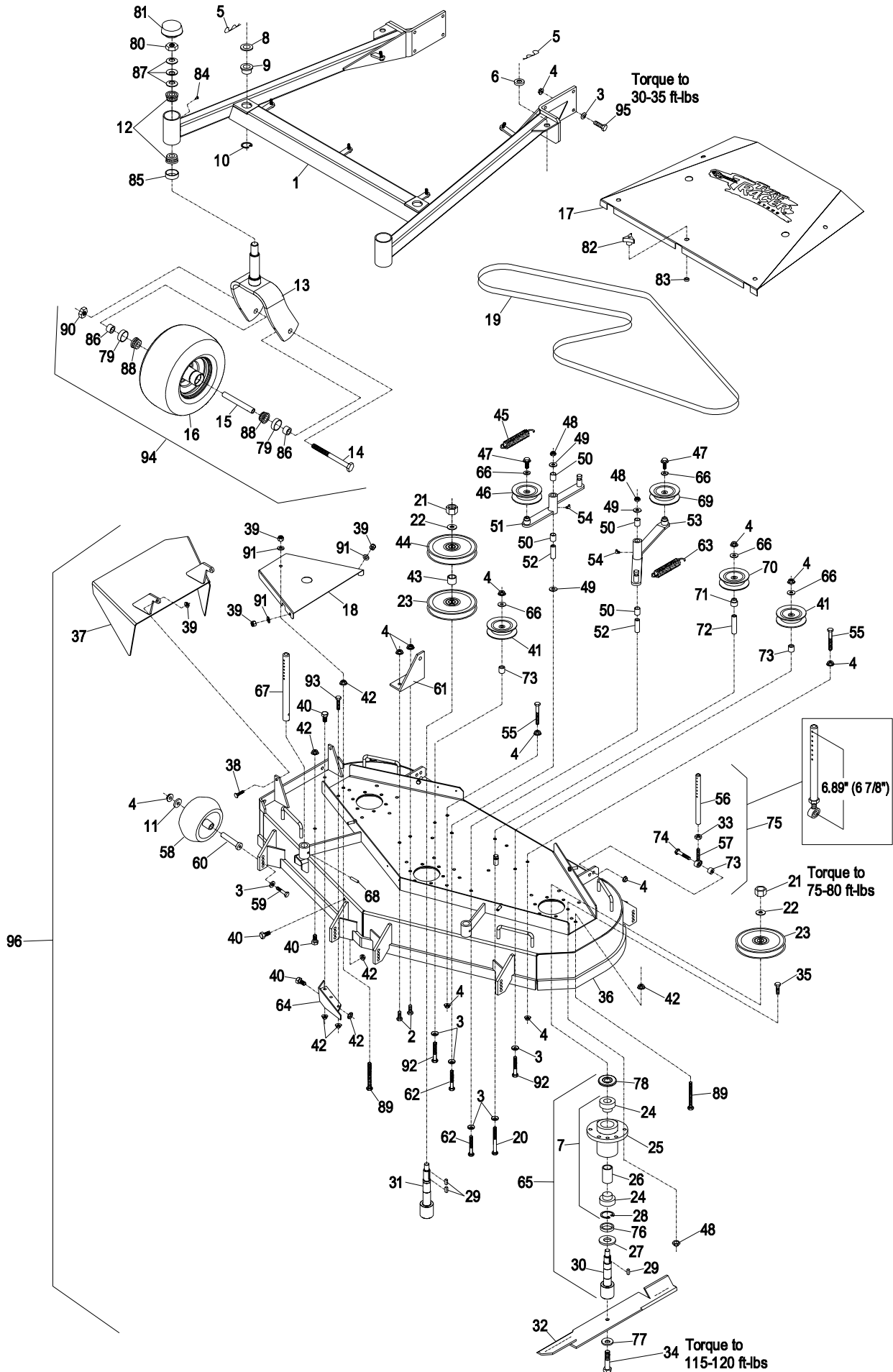

ENGINE DECK GROUP

Ref. No.	Part No.	Description	Qty. Req'd.	Ref. No.	Part No.	Description	Qty. Req'd.
1	103-2235-01	Engine Deck Weldment	1	43	103-0265	Spring, neutral return	2
2*	103-1963	Valve, oil drain (Koh)	1	44	1-603735	Bushing, flanged.	2
3*	103-1965	Valve, oil drain (Kaw).....	1	45	1-303105	Yoke, adjustable.....	2
4	103-1966	Adapter, M20-2.5/ 3/8 NPT...	1	46	322-3	Screw, 5/16-18 x 3/4	15
5	1-602997	Hub, 4 bolt	2	47	323-6	Screw, 3/8-16 x 1	2
	1-633926	Stud	8	48	3290-357	Nut, 3/8-16 whizlock.....	5
6	103-1715	Tire and wheel assy.....	2	49	32128-20	Nut, 5/16-18 whizlock.....	30
	103-2237	Tire only 18 x 8.50	2	50	322-38	Screw, 5/16-18 x 4 1/2	1
	103-2238	Wheel only.....	2	51	322-6	Screw, 5/16-18 x 1 1/4	1
7	242-50	Nut, wheel.....	8	52∇	3212-10	Screw, 7/16-20 x 2 1/2 (Koh)	1
8	1-807019	Key, woodruff 1" x 1/4"	2		3212-12	Screw, 7/16-20 x 3 (Kaw).....	1
9	1-806800	Pin, cotter 9/64 X 1 1/2.....	2	53	1-603610	Washer, spring disc.	2
10	32136-5	Nut, 3/4-16-2B slotted hex....	2	54	1-633545	Spacer, clutch anchor	2
11	1-613089	Anchor, spring	2	55	1-613235	Washer.....	4
12	1-413510	Clip, loom 2.06 dia.	3	56	3296-29	Nut, nylock 5/16-18	7
13	1-807259	Key, 1/4 x 1/4 x 1	1	57	322-7	Screw, 5/16-18 x 1 1/2	4
14	103-2240	Belt, deck drive(52")	1	58	1-303334	Washer, 5/16 disc spring	4
	1-603306	Belt, deck drive(60")	1	59	1-800016	Bolt, tap 5/16-18 x 1 1/4.....	2
15	103-0662	Clutch w/plastic tie.....	1	60∇	323-12	Screw, 3/8-16 x 2 1/2	1
16	1-633543-03	Strap, clutch	1	61	3253-5	Washer, lock 3/8 heavy.....	1
17	1-323195	Standoff, clutch.....	1	62	1-373034	Washer, pivot.....	1
18	1-303287	Plastic tie, small.....	1	63	3231-29	Screw, 3/8-16 x 1 3/4	1
19	1-602438-01	Hitch weldmt.....	1	64	1-806003	Hairpin, cotter.....	2
20•	1-653035	Sheave, 4 1/4 O.D	1	65	1-808280	Clevis pin.....	2
21	1-413010	Sheave, Pump	2	66	3256-23	Washer, 5/16.....	11
22	1-807272	Key, 5mm sq x 25mm.....	2	67	1-403180	Screw, 5/16-18x1-3/8 special	2
23∇	1-803050	Setscrew, 5/16-18 x 3/4.....	4	68	1-603903	Spacer.....	1
24	1-603843	Pulley, idler	1	69	3219-2	Nut 5/16-24 regular	7
25	1-603496	Bushing, idler.....	1	70	3220-2	Nut, 5/16-24 jam	2
26	1-602521	Idler arm w/bushings	1	71	3256-2	Washer, 1/4.....	2
	1-602458	Idler arm weldmt.....	1	72	1-601000	Hitch Kit, sulky.....	1
27	1-603044	Bushing, idler pivot	1	73	322-6	Screw, 5/16-18 x 1-1/4.....	2
28	1-603402	Spring, extension.....	1	74	1-805005	Washer, lock 5/16 heavy.....	4
29	1-513034	Bearing, pivot.....	2	75∇	1-809056	Screw, 3/8 x 3/8 sckt hd shld .	2
30	302-19	Zerk, grease 1/4-20	3	76	3256-24	Washer, 3/8 SAE flat.....	3
31	1-633102	Bearing, flanged	2	77	3234-12	Screw, whizlock 3/8-16 x3/4..	8
32	1-613206	Rod, control arm	2	78	1-633630	Grommet	2
33	1-323245	Spring	1	79	103-1576	Rod, drive lever	2
34	1-603676	Swivel	2	80∇	1-803022	Setscrew, 5/16-18 x 5/8	2
35	1-413151	Knob, tracking.....	1	81	3272-5	Cotter pin.....	2
36	103-2223-01	Support, tank/handle	1	82	1-303335	Plastic tie (large)	1
37	103-1561-01	Arm, control LH	1	83	103-2224	Shield, drag	1
38	103-1562-01	Arm, control RH(not shown)..	1	84	3256-3	Washer, flat 5/16 std.....	3
39	1-613271	Belt, hyd trans drive ("A" Belt).	1	85	3220-16	Nut, jam 3/8-24 LH.....	2
40	1-603693	Spring, extension.....	2	86	103-1167	Joint, .38x.38FE LH ball end.	2
41	103-2234-01	Crank weldmt	1	87	103-2421	Tube, pump link spacer.....	2
42	1-603737	Bolt, neutral return.....	2	88	323-8	Screw, 3/8-16 x 1 1/2	2

Exmark black touch up spray paint - Gloss black

Exmark red touch up spray paint - P/N 1-850337

* Use Teflon Pipe Sealant or equivalent on threads.

• Install sheave with long end of hub up.

ENGINE DECK GROUP

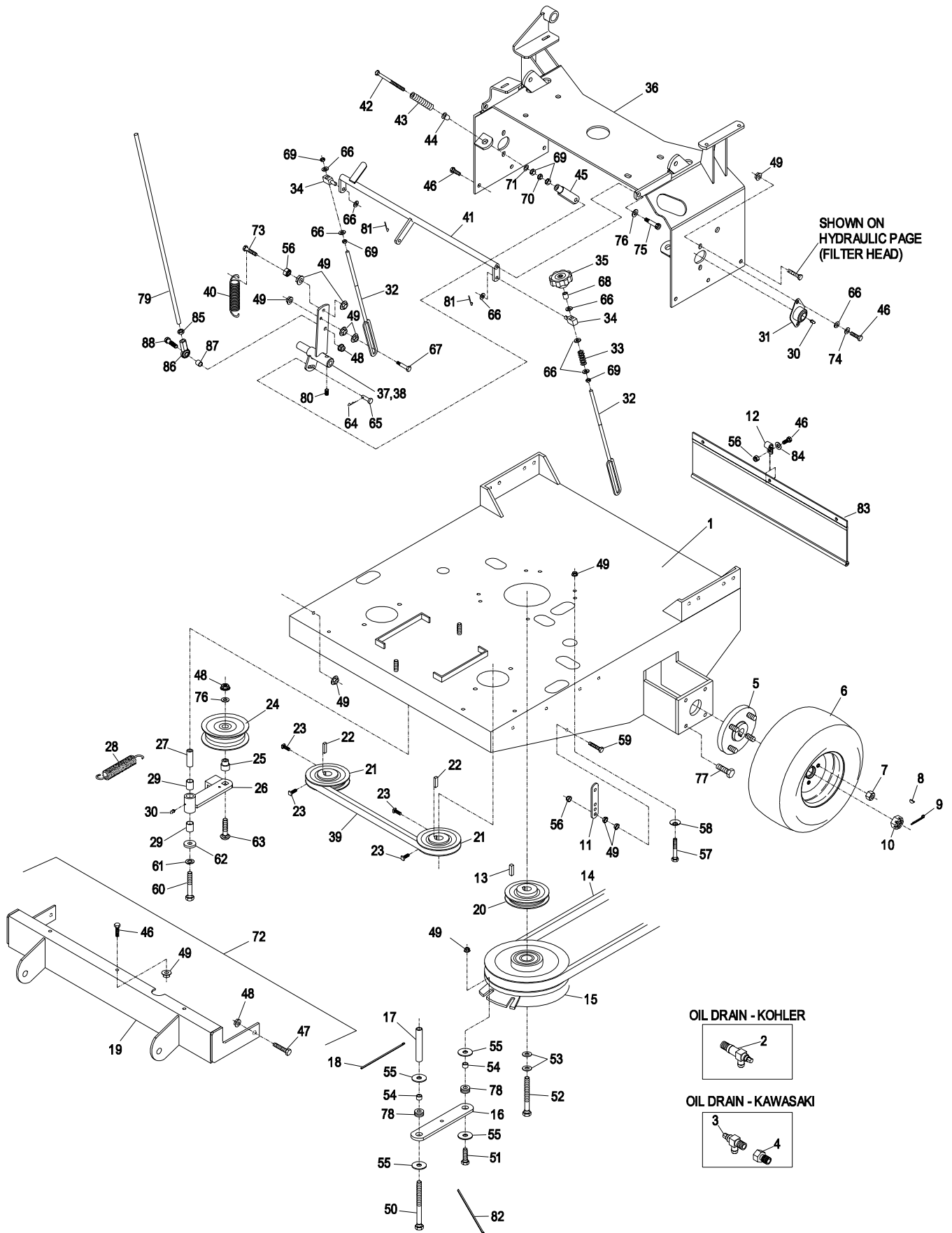

ENGINE DECK GROUP (con't.)

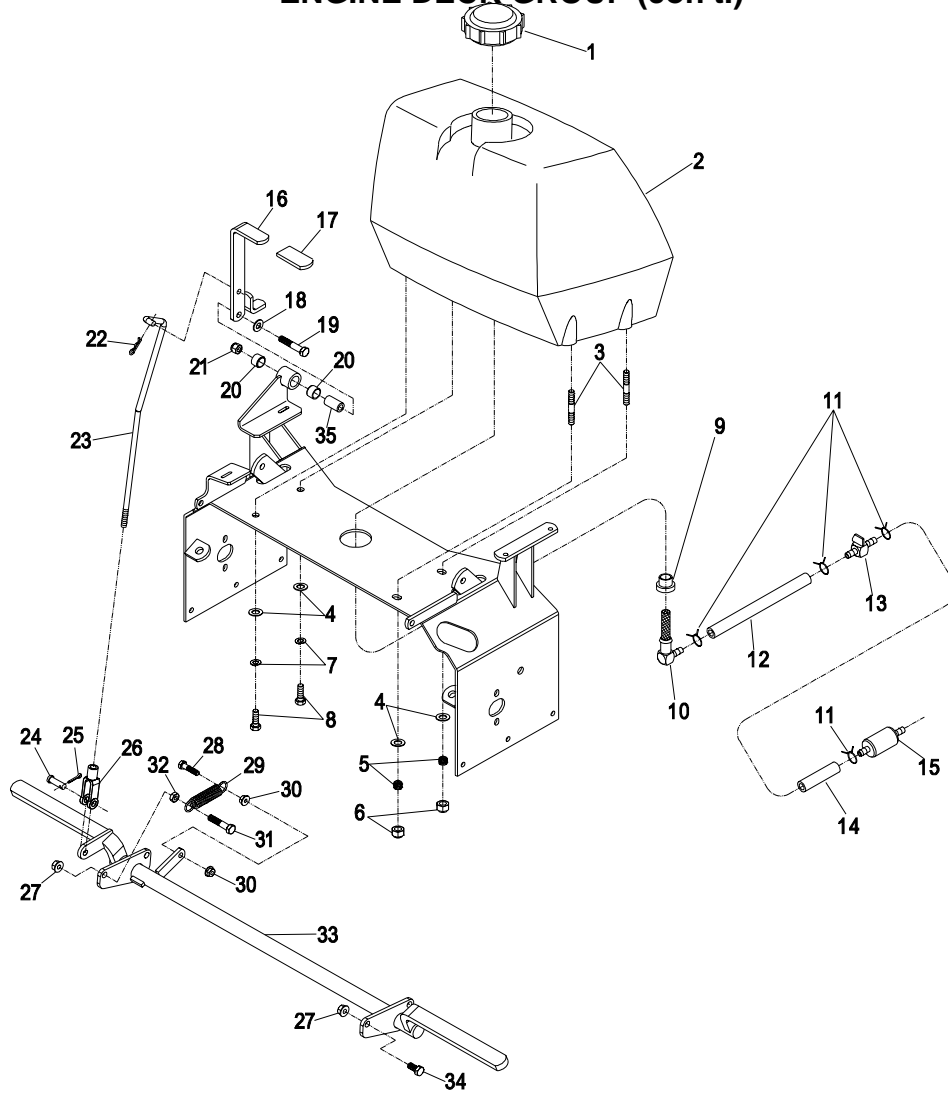

Ref. No.	.Part No.	Description	Qty. Req'd.	Ref. No.	Part No.	Description	Qty. Req'd.
1	1-513508	Cap, gas	1	17	1-303020	Grip, lever	1
2	1-413179	Gas tank	1	18	3256-24	Washer, 3/8 SAE flat	1
3	1-633023	Stud, fuel tank	2	19	323-10	Screw, 3/8-16 x 2	1
4	3256-23	Washer, flat 5/16 std	4	20	1-413347	Sleeve, bushing	2
5	1-633349	Spring, fuel tank.....	2	21	3296-39	Nut, 3/8-16 nyloc.....	1
6	3296-47	Nut, nylock 5/16-18.....	2	22	1-806003	Hairpin, cotter.....	1
7	1-805005	Washer, 5/16 lock.....	2	23	103-1951	Linkage, park brake	1
8	322-3	Screw, 5/16-18 x 3/4.....	2	24	1-808285	Pin, clevis 3/8 x 1 1/8	1
9	1-513645	Bushing, fuel.....	1	25	3272-10	Pin, cotter 1/8 x 3/4	1
10	1-543277	Elbow, fuel tank	1	26	1-633131	Yoke, brake linkage	1
11	1-303077	Clamp, fuel line.....	4	27	3290-357	Nut, 3/8-16 whizlock.....	4
12	1-543649	Hose, fuel 7.0 (Kaw)	1	28	322-6	Screw, 5/16-18 x 1 1/4	1
	1-303022	Hose, fuel 8.5 (Koh).....	1	29	1-323161	Spring.....	1
13	1-603770	Valve, fuel.....	1	30	32128-20	Nut, 5/16-18 whizlock	2
14	1-603776	Hose, fuel 2.5 (Koh).....	1	31	323-9	Screw, 3/8-16 x 1 3/4	1
	1-303022	Hose, fuel 8.5 (Kaw)	1	32	3218-3	Nut, jam 3/8-16	1
15	Kohler Part No. 2405002	fuel filter.....	1	33	103-2205-03	Brake weldmt	1
	Kawasaki Part No. 49019-7001	fuel filter	1	34	323-4	Screw, 3/8-16 x 3/4	3
16	103-2208-03	Park brake lever weldmt.....	1	35	1-413344	Bushing, pivot	1

Exmark black touch up spray paint - Gloss black

- Use Prolock, Retaining type (P/N 1-840023) .5cc tube on studs going into tank

HYDRAULICS GROUP

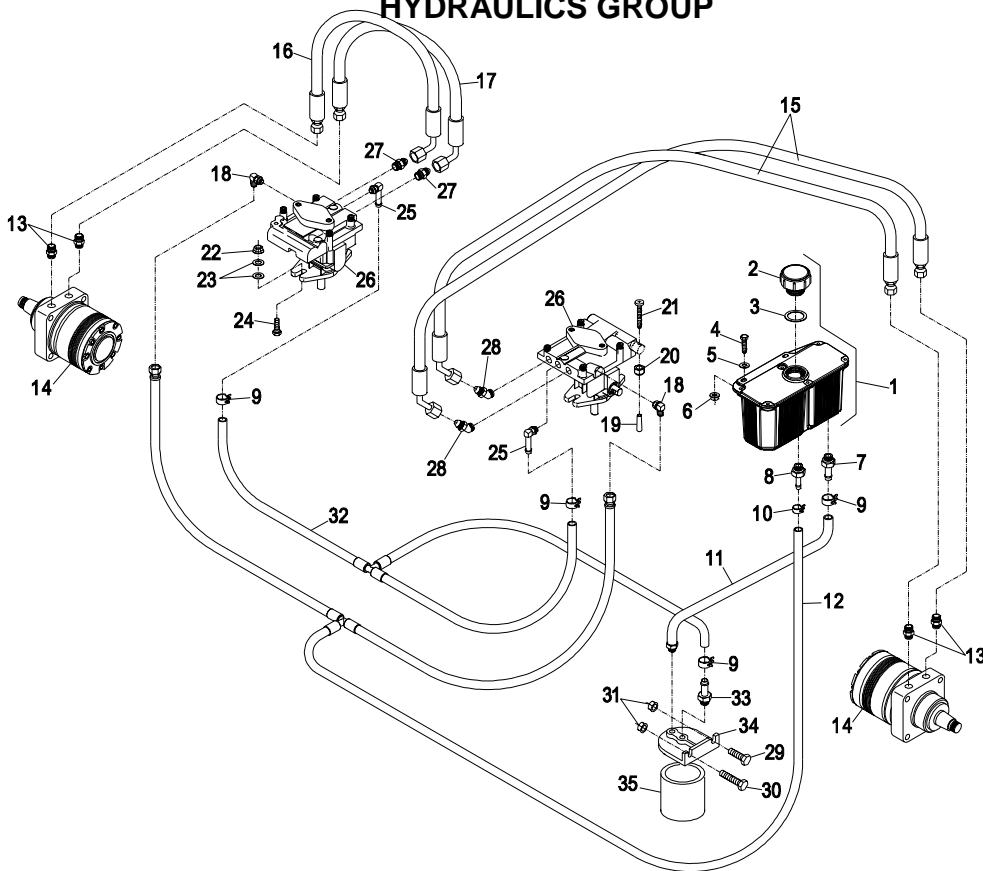

Ref. No.	Part No.	Description	Qty. Req'd.	Ref. No.	Part No.	Description	Qty. Req'd.
1	103-1947	Asm, hydraulic reservoir	1	19	1-613073	Grip, Dump Valve.....	2
2	103-1948	Cap, hydraulic reservoir.....	1	20	3296-42	Nut, nylock 1/4-20	2
3	103-1949	Gasket, reservoir cap	1	21	1-801063	Screw, 1/4-20 x 2 pan hd	2
4	321-6	Screw, 1/4-20 x 1	2	22	3290-357	Nut, whizlock 3/8-16.....	4
5	3256-22	Washer, 1/4 SAE flat	2	23	3256-3	Washer, 5/16 std.....	8
6	32128-33	Nut, whizlock 1/4-20	2	24	323-7	Screw, 3/8-16 x 1-1/4	4
7	103-1912	Adapter, straight	1	25	1-603989	Elbow, 90°	2
	1-603921	O-Ring	1		1-603923	O-Ring.....	1
8	103-1801	Adapter, straight	1	26	1-613042	Pump, hydro.....	2
	1-603921	O-Ring	1		2513018	Kit, overhaul seal.....	1
9	103-1988	Clamp, hose (11/16)	4	27	1-603990	Adapter, straight thread	2
10	103-1716	Clamp, hose (17/32)	1		1-603920	Boss O-Ring.....	1
11	103-2215	Asm, supply hose	1		1-603992	Flare O-Ring	1
12	103-1962	Asm, case drain hose	1	28	1-523221	Elbow, 45	2
13	1-603991	Fitting, straight connector	4		1-603920	Boss O-Ring.....	1
	1-603919	Boss O-Ring	1		1-603992	Flare O-Ring	1
	1-603992	Flare O-Ring	1	29	322-3	Screw, 5/16-18 x 3/4	1
14	1-603718	Motor, wheel	2	30	322-5	Screw, 5/16-18 x 1	1
	1-000119	Kit, seal.....	1	31	32128-20	Nut, whizlock 5/16-18.....	2
	1-000138	Kit, bearing	1	32	103-1961	Asm, charge hose	1
15	1-603981	Hose, hydro (RH).....	2	33	103-1804	Adapter, straight.....	1
16	1-613034	Hose, hydro (LH)	1	34*	1-603720	Head, filter.....	1
17	1-323241	Hose, hydro (LH)	1	35	1-513211	Element, oil filter	1
18	1-513840	Elbow, 90°	2	Δ	1-523541	Element, oil filter(winter)	1
	1-603921	O-Ring	1				

Exmark black touch up spray paint - Gloss black

* Use Teflon Pipe Sealant or equivalent on filter head fittings.

Δ Use only for operation below 32°F(0°C)

ECS UPPER HANDLES & CONTROLS

Ref. No.	Part No.	Description	Qty. Req'd.	Ref. No.	Part No.	Description	Qty. Req'd.
1	322-9	Screw,5/16-18 x 1 3/4.....	2	26	3290-357	Nut, 3/8-16 whizlock.....	4
2	1-806003	Hairpin cotter	2	27	98-5975	Washer, 3/8 disc spring	4
3∇	103-1566-03	Lever weldmt opc LH.....	1	28	323-6	Screw, 3/8-16 x 1	4
4♦	1-803322	Setscrew, 5/16-24 x 5/16...	2	29	3220-3	Nut, jam 3/8-24	4
5	1-303365	Bushing, nylon	2	30	322-10	Screw, 5/16-18 x 2.....	2
6	103-0769-03	Lever axle weldmt, opc.....	1	31	1-603716	Washer, friction disc	1
7	1-303363	Spring, opc extension	1	32	1-323244	Washer, friction.....	2
8∇	103-1567-03	Lever weldmt, opc RH	1	33	103-1538-03	Wld,upper handle console .	1
9	1-807513	Bolt, #10-24 x 1/2 carriage	2		103-1552	Console w/ decals.....	1
10	1-513592	Knob, red throttle	1	34	103-0773	Speed shift weldmt	1
11	1-633696	Cable, throttle	1	35♦	103-0423	Knob .38-16 nyloc	1
12	3296-2	Nut, #10-24 nylock.....	2	36	3296-29	Nut, 5/16-18 nyloc.....	4
13	103-1537-03	Handle wld, upper ecs	1	37	1-323245	Spring, compression	2
14	103-0815	Grip, handle bar.....	2	38	3256-23	Washer 5/16 SAE flat	1
15	1-413152	Bearing	4	39	321-3	Screw, 1/4-20 x 5/8.....	10
16	103-2466-03	Lever, drive LH	1	40	1-413225	Rod, speed control.....	1
17	103-0027	Bushing, drive lever	2	41	3220-2	Nut, 5/16-24 jam	1
18	321-14	Screw,1/4-20 x 2 3/4.....	2	42	1-303105	Yoke.....	1
19	32128-33	Nut, 1/4-20 whizlock	12	43	1-808280	Clevis pin 5/16 x 1.....	1
20	103-0464	Pin,1/8 x 1/2 spring.....	2	44	103-2513	Asm, Drive Lever RH	1
21	3256-22	Washer 1/4 SAE flat.....	10		103-2514	Asm, Drive Lever LH	1
22	1-303435	Washer, 1/4 disc spring.....	6	45	103-2463	Joint,.31 ball end.....	2
23	103-1371	Thumb latch asm RH(shown)	1	46	103-0503	Bracket,shifter slide	1
	103-1372	Thumb latch asm LH	1	47	103-0489-03	Bracket,opc axle	1
24	103-0235	Screw, 1/4-20 x 1-1/8 w/nylon	2	48	3219-3	Nut,reg hex 3/8-24	2
25	103-2465-03	Lever,drive RH.....	1	49	1-603336	Choke control push/pull	1

Exmark black touch up spray paint - Gloss black

- ♦ Use Pro-Lock nut type, Part no. 1-840022 (.5cc tube) on setscrew threads and on shifter knob threads.
- ∇ Use Pro-Lock retaining type, Part no. 1-840023 (.5cc tube) on inside of bore of OPC hub.

ECS UPPER HANDLES & CONTROLS

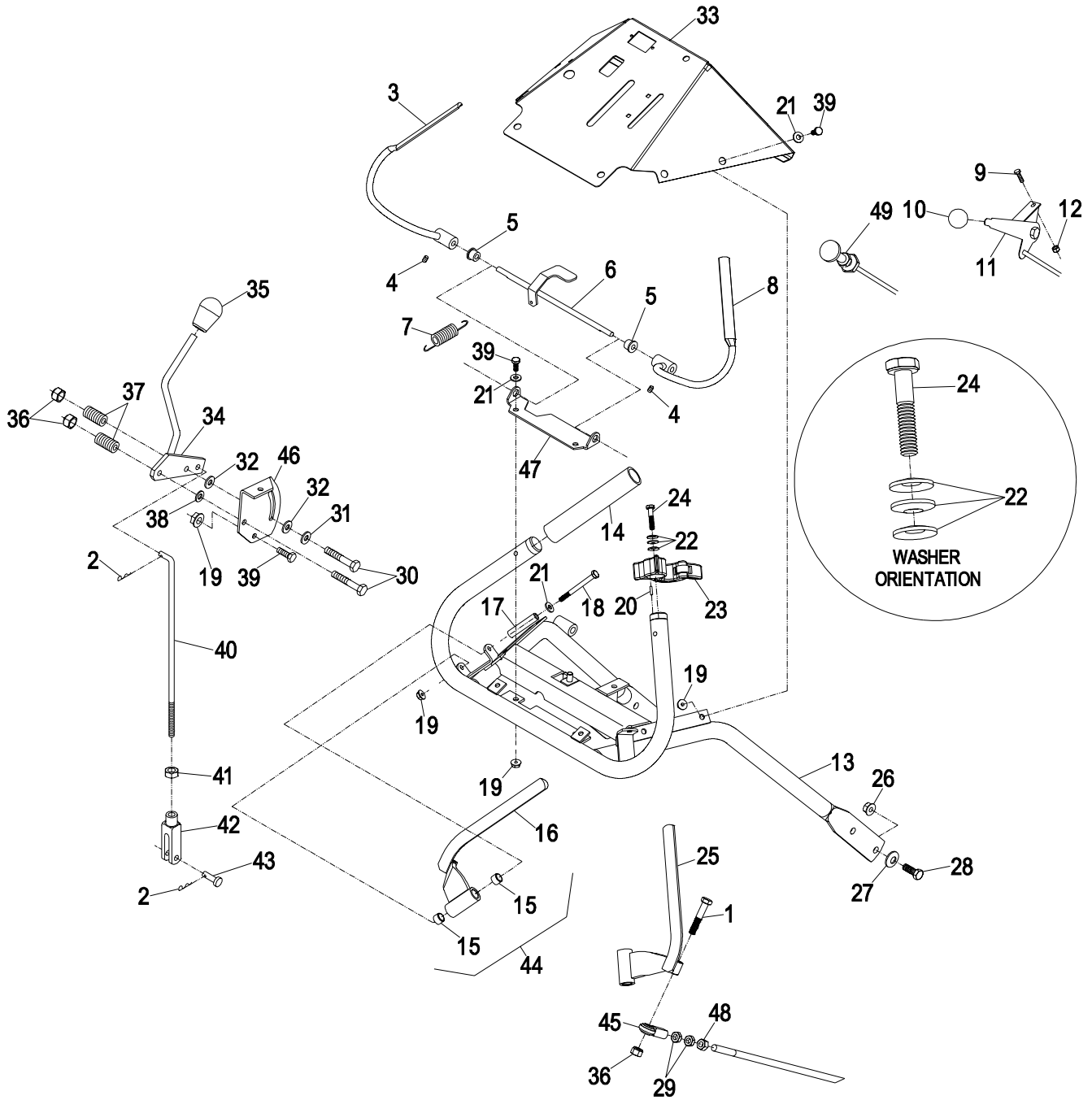

DECALS

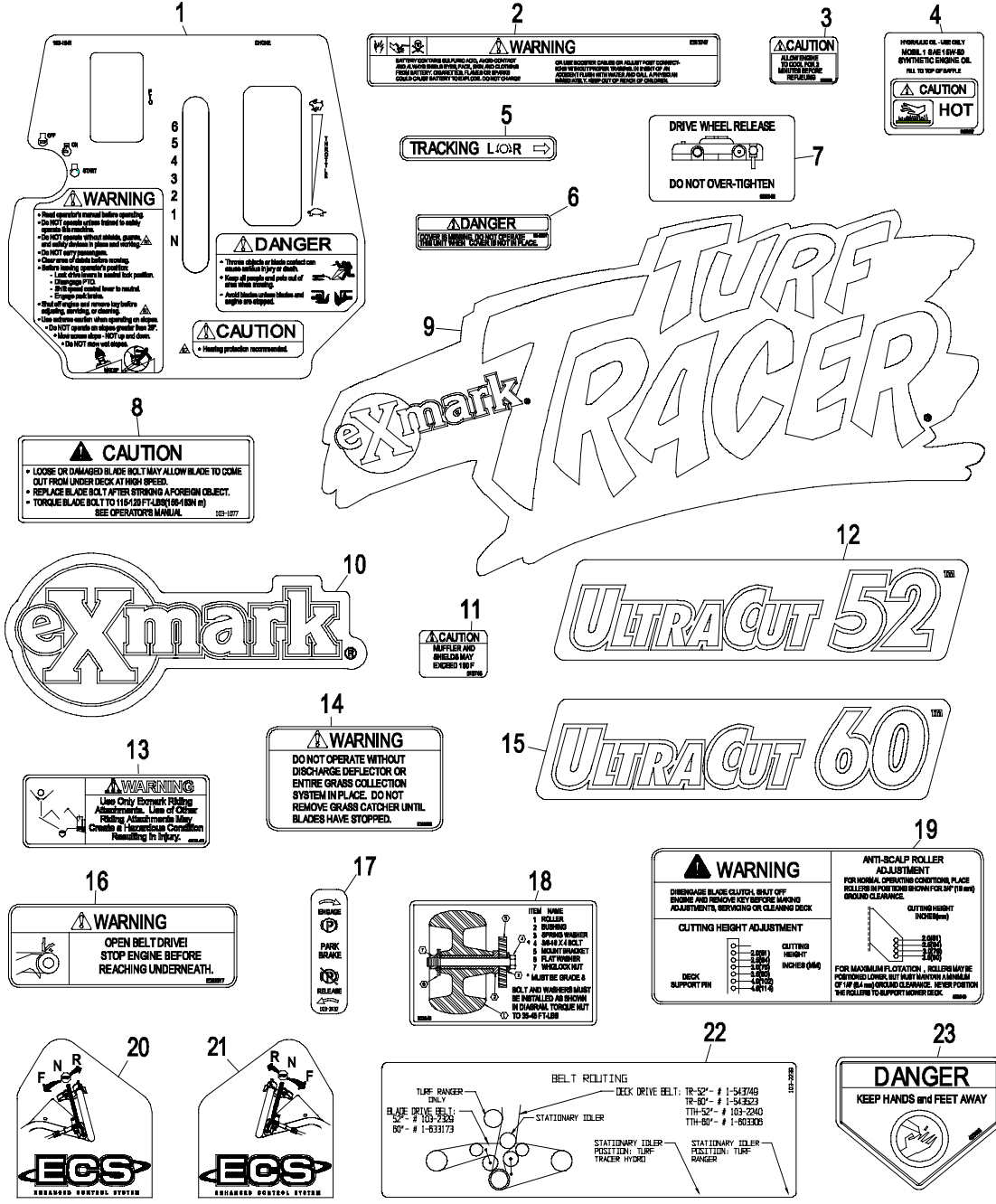

Ref. No.	Part No.	Description	Qty. Req'd.	Ref. No.	Part No.	Description	Qty. Req'd.
1	103-1541	Decal, Console ECS.....	1	13	1-403143	Decal, Sulky Warning.....	1
2	1-513747	Decal, Battery	1	14	1-303508	Decal, Discharge Warning .	1
3	1-303293	Decal, 2 Minute Cool	1	15	103-1146	Decal, Ultracut 60.....	1
4	1-523552	Decal, Hydraulic Tank	1	16	1-303517	Decal, Belt Drive	1
5	1-413214	Decal, Tracking.	1	17	103-2432	Decal, Park Brake	1
6	98-5954	Decal, Missing Cover.....	3	18	1-323540	Decal, Roller Mounting	1
7	1-603845	Decal, Drive Wheel Release	1	19	1-553049	Decal, Mower Deck	1
8	103-1077	Decal, Bolt Torque.....	1	20	103-2242	Decal, LH ECS Instruction .	1
9	103-2417	Decal, "Swash" TTH	1	21	103-2243	Decal, RH ECS Instruction .	1
10	103-1983	Decal, Exmark logo	1	22	103-2239	Decal, Belt Route	1
11	1-513746	Decal, Muffler	1	23	1-403005	Danger Label.....	2
12	103-1145	Decal, Ultracut 52.....	1		103-2551	Kit, Decal Complete	

ELECTRICAL GROUP

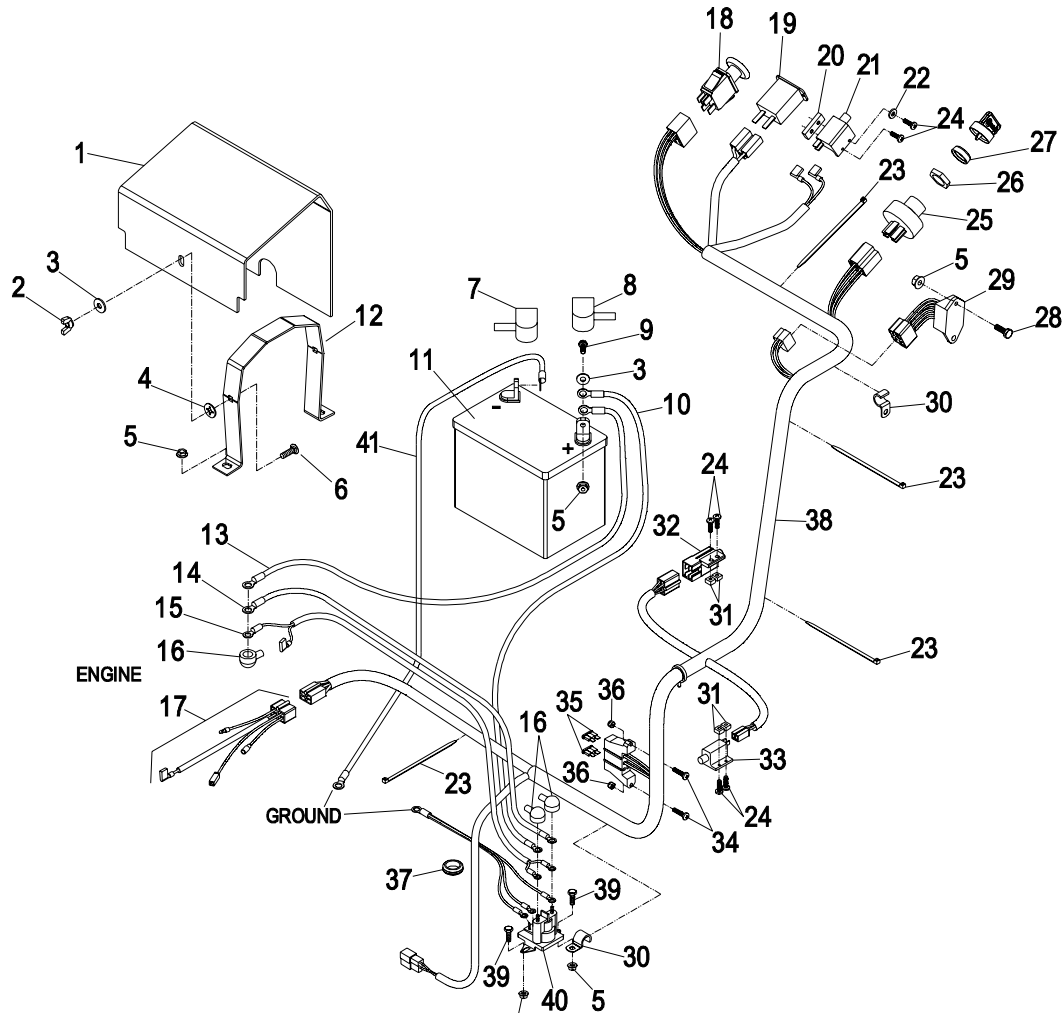

Ref. No.	Part No.	Description	Qty. Req'd.	5	Ref. No.	Part No.	Description	Qty. Req'd.
1	1-603105	Cover, battery debris	1		23	1-303335	Plastic tie	1
2	1-803038	Wingnut, 1/4-20.....	2		24	3290-500	Screw, #10-24x5/8.....	6
3	3256-2	Washer, 1/4 Flat.....	4		25	1-543070	Switch, ignition w/keys.....	1
4	1-803037	Nut, retaining 1/4-20.....	2			1-603511	Key, ignition	1
5	32128-33	Nut, whizlock 1/4-20.....	9			103-2106	Key, Exmark logo.....	1
6	1-807512	Bolt, carriage 1/4-20 x 3/4	2		26	103-0498	Nut, Ignition	1
7	1-543390	Insulator, Battery -	1		27	103-0499	Seal, Ignition.....	1
8	1-543391	Insulator, Battery +	1		28	321-3	Screw, 1/4-20 x 5/8.....	3
9	321-4	Screw, 1/4-20 x 3/4	2		29	1-613198	Module, Safety Interlock	1
10▲	1-513053	Wire, battery to solenoid (+) ...	1		30	103-1193	Clip, Loom half.....	2
11	103-0293	Battery, 12V manifold.....	1		31	1-804002	Nut, square #10-24.....	4
12	1-603814-03	Strap, battery holddown	1		32	1-633111	Switch, N.O./N.C.....	1
13❖	1-523281	Wire, battery to starter.....	1		33	1-513152	Switch, N.C.	1
14▲	1-603488	Wire, solenoid to starter (+).....	1		34	1-803075	Screw, #10-24 x 3/4	2
15❖	103-1126	Harness, solenoid to starter	1		35	1-816001	Fuse, blade 20 amp	2
16	1-543393	Insulator, solenoid.....	3		36	3296-2	Nut, nyloc #10-24.....	2
17▲	1-613262	Harness, wire	1		37	1-543286	Grommet.....	1
18	1-633673	Switch, PTO	1		38	103-1540	Harness, wire.....	1
19	1-513374	Meter, engine hour	1		39	321-2	Screw, 1/4-20 x 1/2.....	2
20	1-633181	Plate, tapped	1		40	1-513075	Switch, 12V solenoid	1
21	1-513051	Switch, N.O.	1		41	1-543767	Wire, ground.....	1
22	3256-14	Washer, flat #10.....	1					

- ❖ Kohler units only.
- ▲ Kawasaki units only.

Apply dielectric grease to all electrical connectors
 Exmark black touch up spray paint - Gloss black

ELECTRICAL DIAGRAM

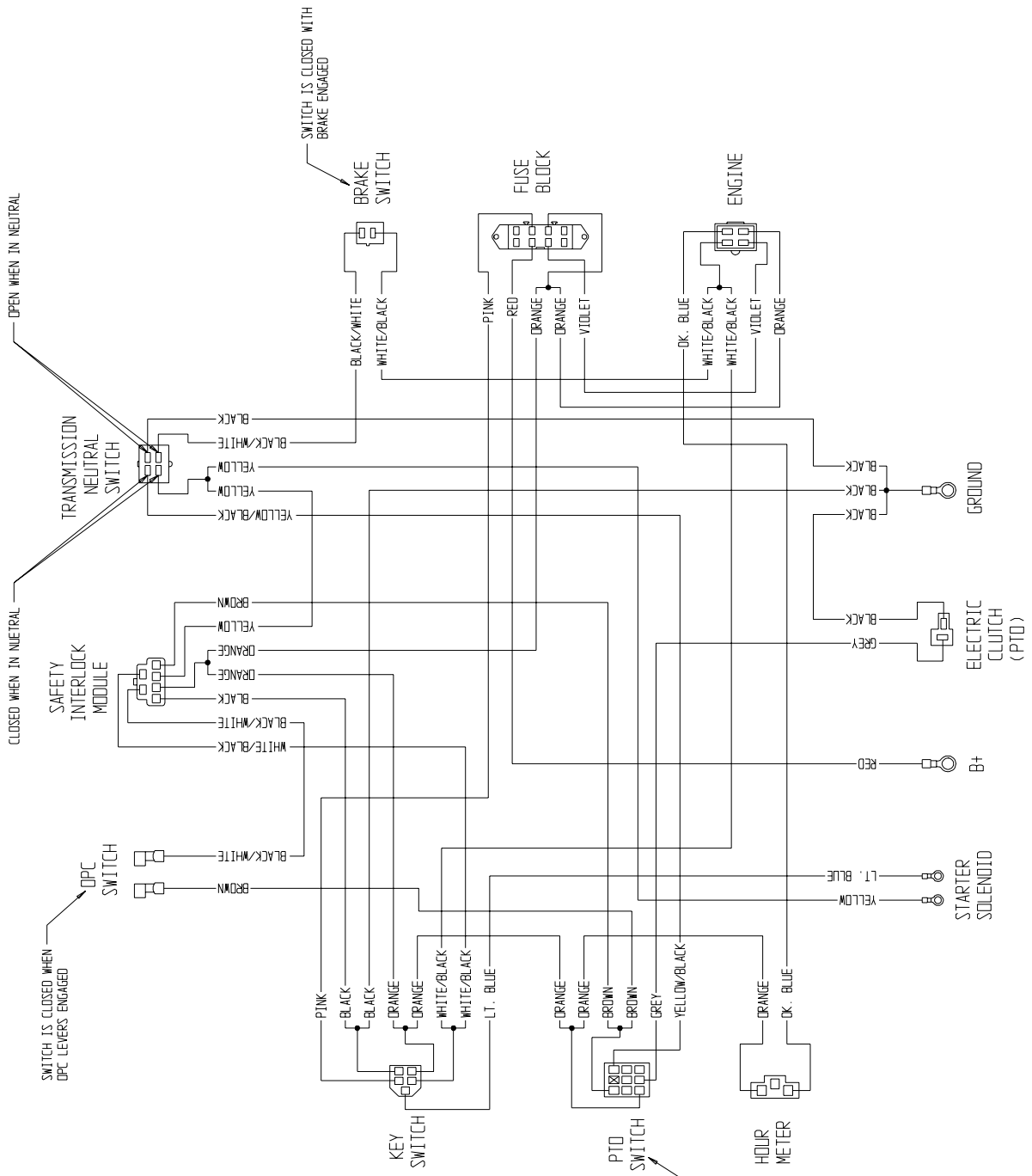

IGNITION SWITCH

TERMINAL	CONNECTIONS
TERMINAL L	PTO, HOUR METER, ENGINE
TERMINAL G	GROUND (-)
TERMINAL B	BATTERY (+)
TERMINAL S	STARTER SOLENOID
TERMINAL M	ENGINE KILL

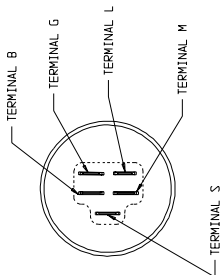

POSITION	CIRCUIT "MAKE"
1. OFF	G + M
2. RUN	B + L
3. START	B + L + S

SWITCH IN - BROWN TO YELLOW/BLACK
 SWITCH OUT - ORANGE TO GREY

NOTES:
 CONNECTORS SHOWN FROM WIRE END.

ELECTRICAL LOGIC SCHEMATIC

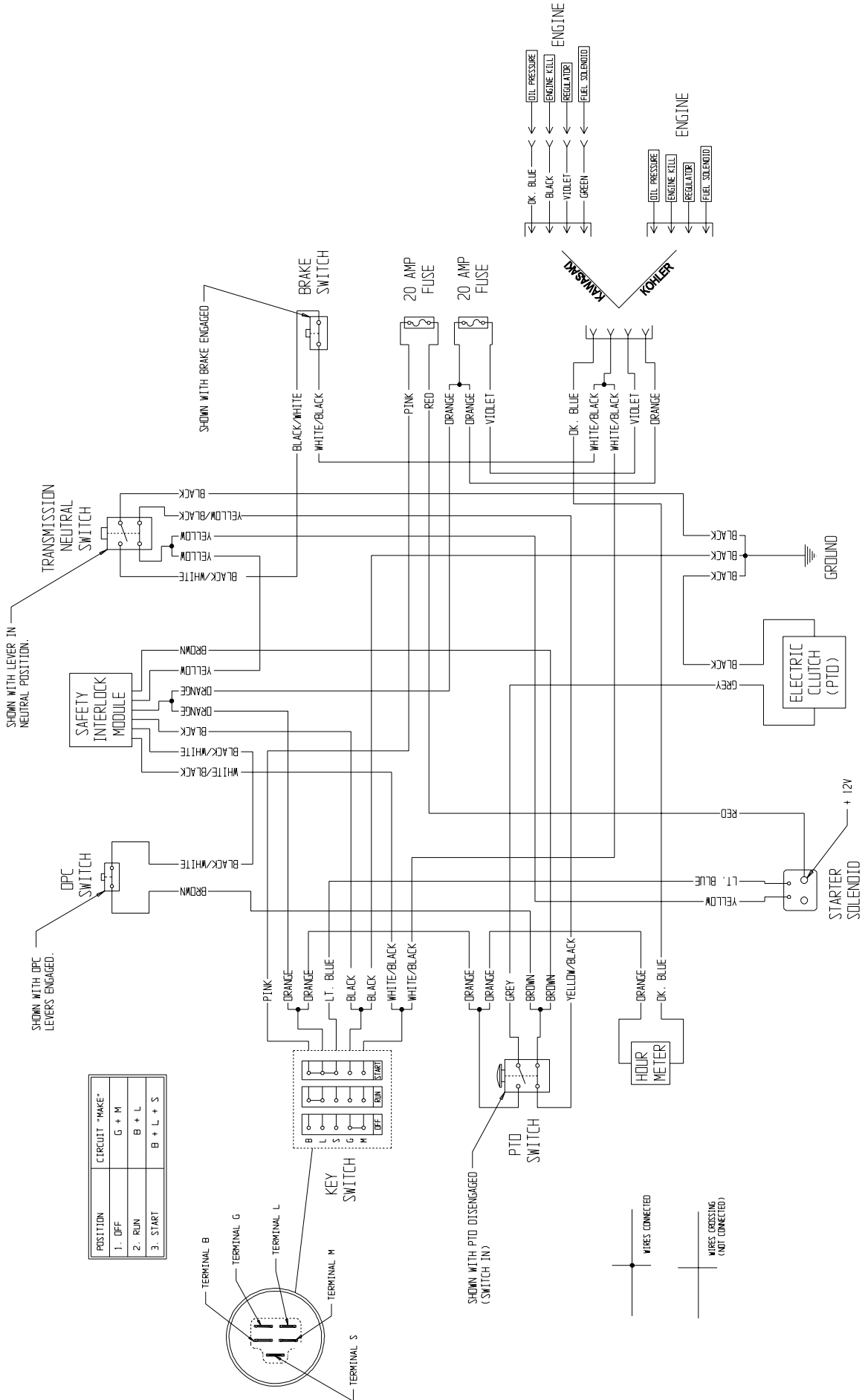

NOTES

SERVICE RECORD

Date	Description of Work Done	Service Done By

**SEE EXMARK'S COMPLETE
LINE OF PRODUCTS FOR TURF CARE**

LAZER Z[®]

LAZER Z[®] HP

LAZER Z[®] XP

TURF RANGER[®]

TURF TRACER[®]

TURF TRACER[®] HP

VIKING HYDRO

METRO[®]

METRO[®] HP

ULTRA VAC[™]

SELF STEERING SULKY

GRASS CATCHER

MICRO-MULCH[™] ACCESSORY

©1997,1998,1999, 2000, 2001
EXMARK MFG. CO. INC.
INDUSTRIAL PARK BOX 808
BEATRICE, NE 68310
ALL RIGHTS RESERVED

PART NO. 103-1559
(402) 223-6300
FAX (402) 223-5489
PRINTED IN U.S.A.

